

API Gate Valve	01-07
API Globe Valve	08-13
API Check Valve	14-19
API Floating Ball Valve	20-25
API Trunnion Ball Valve	26-33
API Butterfly Valve	34-42
API Forged steel gate valves	43-46
API Forged steel globe valves	47-50
API Forged steel check valves	51-53

API Flange size	54-58

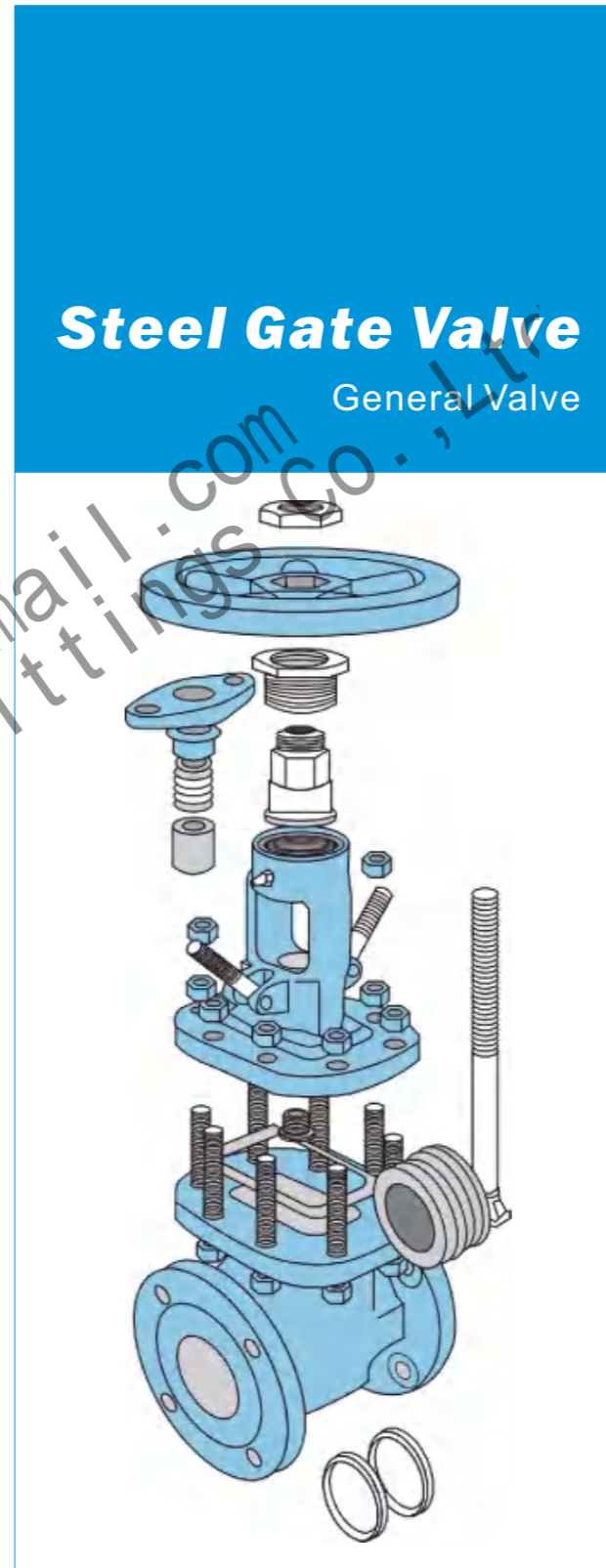

Standards

Design and Manufacture: Cast steel gate valve to API600 (ISO 10434) or API 6D; Cast stainless steel gate valve to API 603 or API 600; Forged steel gate valve to API 602. Inspection and Test: API 598, API 600 or API 6D.

End flange dimension: ASME B16.5 (for NPS ≤ 24) ; ASME B16.47 series B, API 605 or ASME B16.47 series A, MSS SP-44 (for NPS > 24) .

BW end dimension: ASME B16.25.

Socket-weld dimension: ASME B16.11.

Face to face and end to end: ASME B16.10.

Pressure-temperature ratings: ASME B16.34.

Gasket of Cover Flange

Carbon steel or stainless steel + flexible graphite combined gasket is used for Class150 gate valve; Stainless steel + flexible graphite wounded gasket is used for Class 300 gate valve; Stainless steel + flexible graphite wounded gasket is used for Class600 gate valve and ring joint gasket is also optional for Class600 gate valve; Ring Joint gasket is used for Class 900 gate valve; Pressurized seal design is used for Class1500 ~ Class2500 gate valve.

Packing Seal

Molded flexible graphite is used for packing material. PTFE or combined packing material can be also used if being requested by the customer. The internal surface of the stuffing box, of which area is contacted with the packing, is of excellent finish (Ra3.2 μ m). The stem surface, contacting with the packing, should be rolled and pressed after being precisely machined, so as to reach to the high finish and compactness (Ra0.8 μ m) and ensure the reliable tightness of the stem area.

Back Seating Design

All our gate valves have the back seating design. In most cases, the carbon steel gate valve is fitted with a renewable back seat. For stainless steel gate valve, the back seat is machined directly in the bonnet or is machined after welding. When the gate valve is at fully open position, the sealing of the back seat can be very reliable. However, as per the requirement of API 600, it is not advisable to add or change packing by the mean of back seating when the valve is Pressure containing.

Stem Design

The stem is of integral forged design. The minimum diameter of the stem shall per the standard requirement. The connection of the stem and disc is T type. The strength of the connecting area is bigger than that of the T threaded part of the stem. The strength test of that area conforms to API 591.

GENERAL VALVE

Body and Bonnet Connection

The body and bonnet of Class150 ~ Class900 gate valves are usually connected with studs and nuts. And the body and bonnet of Class1500 ~ Class2500 gate valves are usually of pressure seal design.

Design of Disc

Gate Valves with NPS ≥ 2 are of wedge flexible gate; Gate valves with NPS < 2 are of wedge solid gate.

Actuation

Hand wheel or gear box is usually used for gate valve actuation. Chain wheel and electric actuator can be also used for gate valve actuation if being requested by the customers.

Stem Nut

Usually, the stem nut is made of copper alloy. it is also can be made of ASTM A439 D2 if being requested by the customer. For large sized gate valves (NPS 10 for Class 150, NPS 8 for Class 300, NPS 6 for Class 600, NPS 5 for Class 900), rolling bearing is fitted at the two sides of the stem nut in order to minimize the open and close torque of the gate valve.

Seat

For carbon steel gate valve, the seat is usually forged steel. The sealing surface of the seat is spray welded with hard alloy specified by the customer. Renewable threaded seat is used for NPS ≤ 10 gate valves, and welded on seat can be also optional if being requested by the customer. Welded on seat is used for NPS ≤ 10 carbon steel gate valves. For Stainless steel gate valve, integral seat is usually adopted, or to weld hard alloy directly integrally. Threaded or welded on seat is also optional for stainless steel gate valve if being requested by the customer.

Special Gate Valve

Besides the common gate valves, We also makes cryogenic gate valve, Jacketed Gate Valve, Bellow Sealed Gate Valve, Extension Stem Gate Valve for underground application, Slat Gate Valve, etc.

Belleville Spring Loaded Packing Impacting System

If being requested by the customer, the Belleville spring loaded packing impacting system can be adopted for enhancing the durability and reliability of the packing seal.

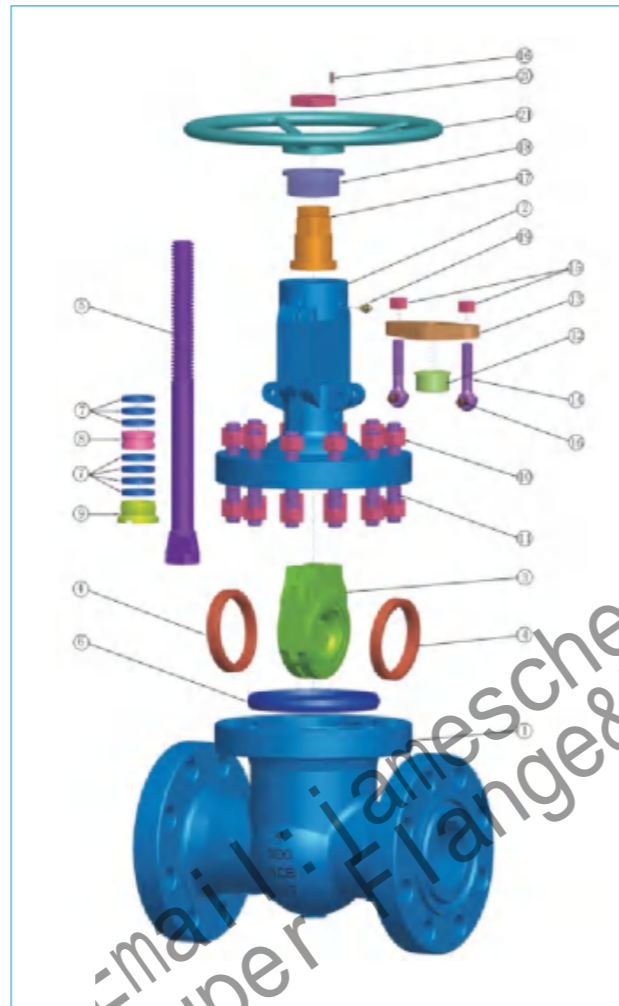

No	Part Name	No	Part Name	No	Part Name
1	Body	8	Lantern Ring	15	Gland Nut
2	Bonnet	9	Backseat Bushing	16	Pin
3	Wedge	10	Nut	17	Stem Nut
4	Seating Ring	11	Bolt	18	Retaining Nut
5	Stem	12	Gland	19	Nipple
6	Gasket	13	Gland Flange	20	H.W.Lock Nut
7	Stem Packing	14	Gland Eyebolt	21	Handwheel

GENERAL VALVE



API600 Trim material

Trim code	Seat ring surface	Wedge seat surface	Stem & backseat bushing
1	13Cr	13Cr	A182 F6a
2	18Cr-8Ni	18Cr-8Ni	A182 F304
3	25Cr-20Ni	25Cr-20Ni	A182 F310
4	Hard 13Cr	Hard 13Cr	A182 F6a
5	Stellite	Stellite	A182 F6a
6	13Cr	Cu-Ni Alloy	Monel
7	13Cr	Hard 13Cr	A182 F6a
8	Stellite	13Cr	A182 F6a
9	Cu-Ni Alloy	Cu-Ni Alloy	Monel
10	18Cr-8Ni-Mo	18Cr-8Ni-Mo	A182 F316
11	Cu-Ni Alloy	Cu-Ni Alloy	Monel
12	Stellite	18Cr-8Ni-Mo	A182 F316
13	19Cr-29Ni	19Cr-29Ni	20 Alloy

ASTM Material list of API600 Rising Stem Cast Steel Gate Valve

No	Part Name	Carbon Steel to ASTM		Stainless Steel to ASTM			Alloy Steel to ASTM			
1	Body	A216 WCB	A352 LCB	A351 CF8	A351 CF8M	A351 CF3	A351 CF3M	A217 WC6	A217 WC9	A217 C5
2	Bonnet	A216 WCB	A352 LCB	A351 CF8	A351 CF8M	A351 CF3	A351 CF3M	A217 WC6	A217 WC9	A217 C5
3	Wedge	A216 WCB	A352 LCB	A351 CF8	A351 CF8M	A351 CF3	A351 CF3M	A217 WC6	A217 WC9	A217 C5
4	Seating Ring	A105N	A350LF2	A351 CF8	A351 CF8M	A351 CF3	A351 CF3M	A182 F11	A182 F22	A182 F5
5	Stem	A182 F6a	A182 F304	A182 F304	A182 F316	A182 F304L	A182 F316L	A182 F304		
6	Gasket	Graphite+SS304, PTFE								
7	Stem Packing	Flexible Graphite								
8	Lantern Ring	A182 F6a	A182 F304	A182 F304	A182 F316	A182 F304L	A182 F316L	A182 F304		
9	Backseat Bushing	A182 F6a	A182 F304	A182 F304	A182 F316	A182 F304L	A182 F316L	A182 F304		
10	Nut	A194 2H	A194 4	A194 8				A194 7		
11	Bolt	A193 B7	A320 L7	A193 B8				A193 B16		
12	Gland	F6a	A182 F304	A182 F304	A182 F316	A182 F304L	A182 F316L	A182 F304		
13	Gland Flange	A216 WCB	A352 LCB	A351 CF8	A351 CF8	A351 CF8	A351 CF8	A217 WC6	217 WC9	A217 C5
14	Gland Eyebolt	A193 B7		A193 B8				A193 B16		
15	Gland Nut	A194 2H		A194 8				A194 7		
16	Pin	ANSI 1045		A182 F304				ANSI 1045		
17	Stem Nut	A439 D2 / B148 952A								
18	Retaining Nut	ANSI 1020								
19	Nipple	Copper Alloy								
20	H.W.Lock Nut	ANSI 1020								
21	Handwheel	A197								

* Suitable for H₂S service and meet requirement of NACE MR 0175.

API Steel Gate Valve

GENERAL VALVE

Construction feature

- Bolted bonnet
- Flexible or solid wedge
- Renewable seat
- (Threaded or welded seat ring)
- ≤ 8" Yoke integral with bonnet
- ≥ 10" Separate yoke bolted to bonnet

API598 Pressure Test

- Pressure ratings: Class150
- Hydraulic Shell test: 3.2MPa
- Hydraulic Seat test: 2.2MPa
- Air test: 0.6MPa

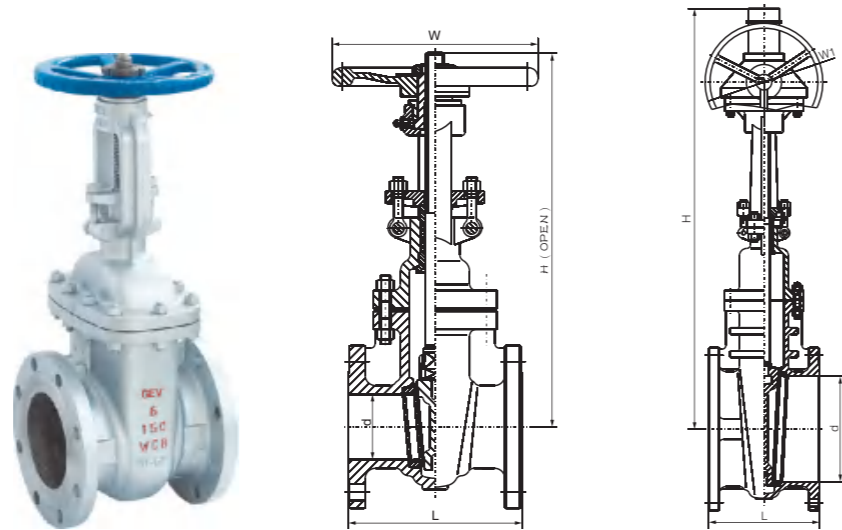

Main size of outside & weight

Class	Size		Dimensions (mm)								Weight (Kg)	
	NPS	DN	L			d	H	H1	W	W1	Hand wheel	Gear box
			RF	RTJ	BW							
Class 150	2	50	178	191	216	51	400	-	200	-	19	-
	2 1/2	65	190	203	241	64	435	-	200	-	25	-
	3	80	203	216	283	76	515	-	250	-	33	-
	4	100	229	241	305	102	595	-	280	-	49	-
	5	125	254	267	381	127	725	-	280	-	62	-
	6	150	267	279	403	152	780	820	300	310	77	104
	8	200	292	305	419	203	975	1020	350	310	123	150
	10	250	330	343	457	254	1150	1200	400	310	168	215
	12	300	356	368	502	305	1380	1430	450	310	288	315
	14	350	381	394	572	337	1545	1580	500	310	385	435
	16	400	406	419	610	387	1733	1780	500	460	500	552
	18	450	432	445	660	438	1915	1990	500	460	601	653
	20	500	457	470	711	489	2122	2220	600	460	764	816
	24	600	508	521	813	591	2520	2600	600	460	1007	1185
	28	700	610	623	914	684	-	3050	-	600	-	1880
	30	750	610	623	914	735	-	3130	-	600	-	2300
	32	800	660	673	965	779	-	3280	-	600	-	2550
	36	900	711	724	1016	874	-	3720	-	600	-	3390
40	1000	762	-	1066	-	-	4100	-	-	-	4880	
42	1050	787	-	1092	-	-	4300	-	-	-	5300	
48	1200	864	-	1168	-	-	5080	-	-	-	7520	

API Steel Gate Valve

GENERAL VALVE

Construction feature

- Bolted bonnet
- Flexible or solid wedge
- Renewable seat
- (Threaded or welded seat ring)
- ≤ 8" Yoke integral with bonnet
- ≥ 10" Separate yoke bolted to bonnet

API598 Pressure Test

- Pressure ratings: Class300
- Hydraulic Shell test: 7.8MPa
- Hydraulic Seat test: 5.7MPa
- Air test: 0.6MPa

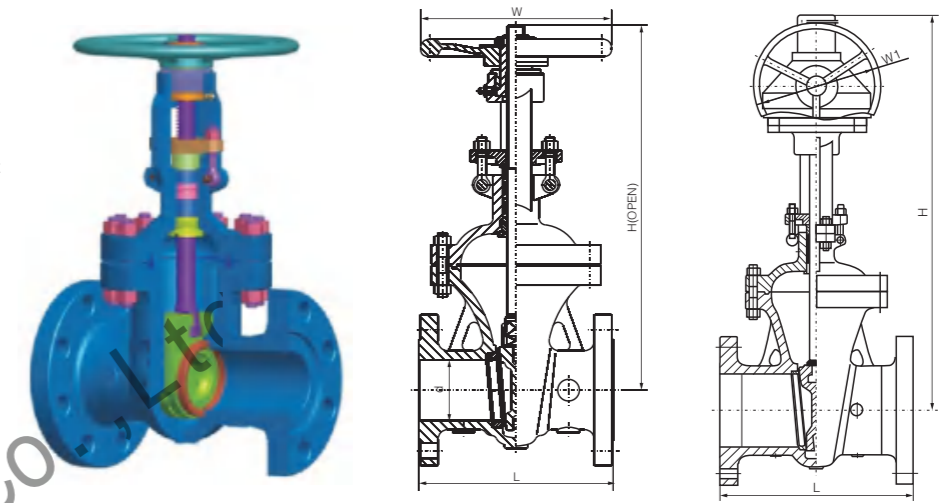

Main size of outside & weight

Class	Size		Dimensions (mm)								Weight (Kg)	
	NPS	DN	L			d	H	H1	W	W1	Hand wheel	Gear box
			RF	RTJ	BW							
Class 300	2	50	216	232	216	51	420	-	200	-	25	-
	2 1/2	65	241	257	241	64	446	-	200	-	30	-
	3	80	283	298	283	76	537	-	250	-	48	-
	4	100	305	321	305	102	619	650	280	310	73	100
	5	125	381	397	381	127	722	750	300	310	99	126
	6	150	403	419	403	152	806	835	350	310	130	186
	8	200	419	435	419	203	1000	1030	400	310	208	235
	10	250	457	473	457	254	1240	1280	450	310	334	386
	12	300	502	518	502	305	1425	1460	500	310	450	502
	14	350	762	778	762	337	1585	1620	600	460	704	756
	16	400	838	854	838	387	1790	1830	500	460	923	965
	18	450	914	930	914	438	1960	2000	650	460	1131	1224
	20	500	991	1010	991	489	2158	2220	750	460	1345	1400
	24	600	1143	1165	1143	584	2576	2620	900	600	2122	2385
	28	700	1346	1372	1346	684	-	3080	-	600	-	3300
	30	750	1397	1422	1397	735	-	3180	-	600	-	3550
	32	800	1524	1553	1524	779	-	3300	-	600	-	4400
	36	900	1727	1756	1727	874	-	3760	-	600	-	6050

API Steel Gate Valve

GENERAL VALVE

Construction feature

- Bolted bonnet
- Flexible or solid wedge
- Renewable seat
- (Threaded or welded seat ring)
- ≤6" Yoke integral with bonnet
- ≥8" Separate yoke bolted to bonnet

API598 Pressure Test

Pressure ratings: Class600
 Hydraulic Shell test: 15.6MPa
 Hydraulic Seat test: 11.4MPa
 Air test: 0.6MPa

Pressure ratings: Class900
 Hydraulic Shell test: 23.3MPa
 Hydraulic Seat test: 17.1MPa
 Air test: 0.6MPa

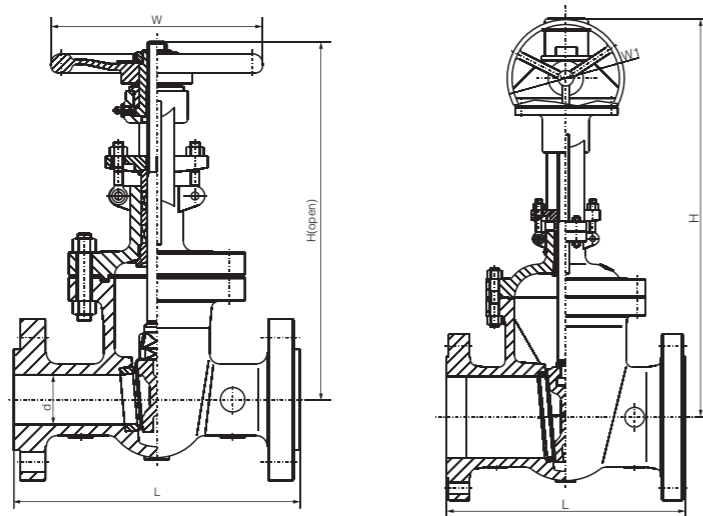

Main size of outside & weight

Class	Size		Dimensions (mm)								Weight(Kg)	
	NPS	DN	L			d	H	H1	W	W1	Hand wheel	Gear box
			RF	RTJ	BW							
Class 600	2	50	292	295	292	51	444	-	200	-	32	-
	2 1/2	65	330	333	330	64	500	-	250	-	52	-
	3	80	356	359	356	76	558	585	280	310	60	87
	4	100	432	435	432	102	665	695	300	310	107	134
	5	125	508	511	508	127	760	790	350	310	175	227
	6	150	559	562	559	152	868	900	450	310	216	268
	8	200	660	664	660	200	1073	1110	500	310	399	451
	10	250	787	791	787	248	1263	1300	650	460	605	657
	12	300	838	841	838	298	1600	1650	700	460	851	893
	14	350	889	892	889	327	1705	1750	900	460	1177	1232
16	400	991	994	991	375	1835	1900	900	460	1513	1568	
18	450	1092	1095	1092	419	-	2020	-	600	-	1980	
20	500	1194	1200	1194	464	-	2172	-	600	-	2460	
24	600	1397	1407	1397	559	-	2650	-	600	-	3650	
Class 900	2	50	368	371	368	47	500	-	280	-	70	-
	2 1/2	65	419	422	419	57	550	-	280	-	110	-
	3	80	381	384	381	73	610	660	300	310	140	167
	4	100	457	460	457	98	702	750	350	310	200	227
	5	125	559	562	559	121	850	900	400	310	258	285
	6	150	610	613	610	146	980	1060	500	460	358	410
	8	200	737	740	737	190	1100	1140	650	460	550	600
	10	250	838	841	838	234	1320	1370	700	460	1000	1100
	12	300	965	968	965	282	1500	1560	900	460	1215	1310
	14	350	1029	1038	1029	311	1900	1950	900	600	1600	1700
16	400	1130	1140	1130	354	2050	2100	900	600	2150	2330	

API Steel Gate Valve

GENERAL VALVE

Construction feature

- Bolted bonnet
- Flexible or solid wedge
- Renewable seat
- (Threaded or welded seat ring)
- ≤6" Yoke integral with bonnet
- ≥8" Separate yoke bolted to bonnet

API598 Pressure Test

Pressure ratings: Class1500
 Hydraulic Shell test: 38.8MPa
 Hydraulic Seat test: 28.5MPa
 Air test: 0.6MPa

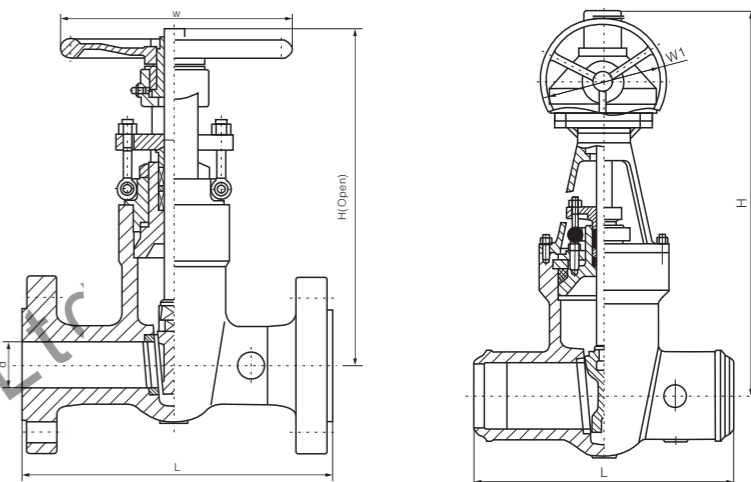

Main size of outside & weight

Class	Size		Dimensions (mm)								Weight(Kg)	
	NPS	DN	L			d	H	H1	W	W1	Hand wheel	Gear box
			RF	RTJ	BW							
Class 1500	2	50	368	371	368	47	510	-	280	-	70	-
	2 1/2	65	419	422	419	57	560	-	300	-	110	-
	3	80	470	473	470	70	620	670	350	310	175	202
	4	100	546	549	546	92	728	770	400	310	270	300
	5	125	673	676	673	111	870	920	450	310	378	405
	6	150	705	711	705	136	1000	1070	500	460	520	575
	8	200	832	841	832	174	1130	1180	750	460	820	915
	10	250	991	1000	991	222	1360	1410	900	600	1560	1750
	12	300	1130	1146	1130	263	-	1620	-	600	-	2120
	14	350	1257	1276	1257	289	-	2020	-	600	-	2600
16	400	1384	1407	1384	330	-	2180	-	600	-	3450	
Class 2500	2	50	451	454	451	35	530	580	280	310	100	130
	2 1/2	65	508	514	508	47	580	630	300	310	150	180
	3	80	578	584	578	57	650	700	350	310	245	275
	4	100	673	683	673	73	750	800	400	310	390	420
	5	125	794	807	794	92	900	960	500	460	550	580
	6	150	914	927	914	111	1040	1100	600	460	780	835
	8	200	1022	1038	1022	146	1150	1200	750	460	1260	1355
	10	250	1270	1292	1270	184	1400	1460	900	600	2380	2565
	12	300	1422	1445	1422	219	-	1660	-	600	-	3250

Steel Globe Valve General Valve

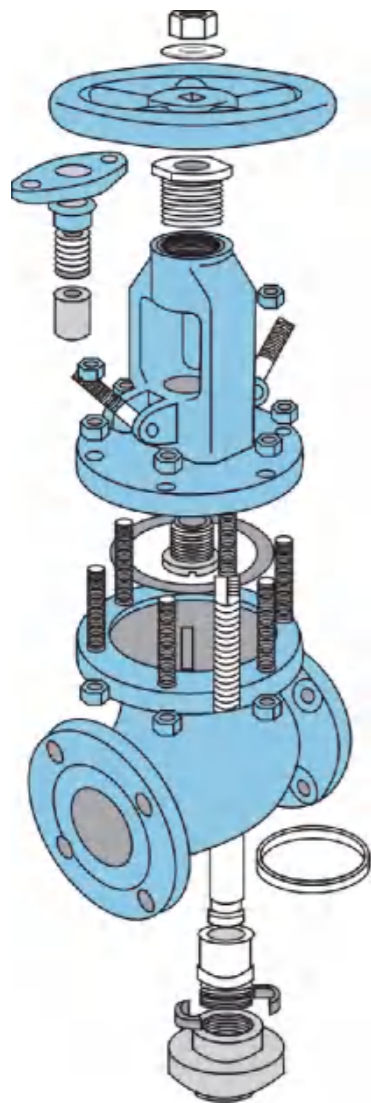

Standards

Design and Manufacture: Cast steel globe valve to BS 1873 and ASME B16.34; Forged steel globe valve to API 602.
 Inspection and Test: API 598.
 End flange dimension: ASME B16.5.
 BW end dimension: ASME B16.25.
 Socket-weld dimension: ASME B16.11.
 Face to face and end to end: ASME B16.10.
 Pressure-temperature ratings: ASME B16.34.

The features of globe valve

Bolted Bonnet; Outside Screw and Yoke; Rising stems; Metallic seating surfaces.

Body and Bonnet Connection

The body and bonnet of Class150 ~ Class900 globe valves are usually with studs and nuts. And the body and bonnet of Class1500 ~ Class2500 globe valves are usually of pressure seal design.

Gasket of Cover Flange

Stainless steel + flexible graphite wounded gasket is used for Class150 and Class300 globe valve. Stainless steel + flexible graphite wounded gasket is used for Class 600, and ring joint gasket is also optional for Class600. Ring joint gasket is used for Class900 globe valve. Pressurized seal design is used for Class 1500 ~ Class2500 globe valve.

Actuation

Hand wheel, impact hand wheel & gear box is usually used for globe valve actuation. Chain wheel and electric actuator can be also used for globe valve actuation if being requested by the customers.

Packing Seal

Molded flexible graphite is used for packing material. PTFE or combined packing material can be also used if being requested by the customer. The internal surface of the stuffing box, of which area is contacted with the packing, is of excellent finish (Ra 3.2 μm). The stem surface, contacting with the packing, should be rolled and pressed after being precisely machined, so as to reach to the high finish and com-pactness (Ra 0.8 μm) and ensure the reliable tightness of the stem area.

Belleville Spring Loaded Packing Impacting System

If being requested by the customer, the Belleville spring loaded packing impacting can be adopted for enhancing the durability and reliability of the packing seal.

Back Seating Design

All our globe valves have the back seat design. In most cases, the carbon steel globe valve is fitted with a renewable back seat. For stainless steel globe valve, the back seat is machined directly in the bonnet or is machined after welding. When the globe valve is at fully open position, the sealing of the back seat can be very reliable. However, as per the requirement of API, it is not advisable to add or change packing by the mean of back seating when the valve is pressure containing.

Seat

For carbon steel globe valve, the seat is usually forged steel. The sealing surface of the seat is spray welded with hard alloy specified by the customer. Renewable threaded seat is used for NPS ≤ 10 globe valve and welded on seat can be also optional if being requested by the customer. Welded on seat is used for NPS ≥ 12 carbon steel globe valves. For stainless steel globe valve, integral seat is usually adopted, or to weld hard alloy directly integrally. Threaded or welded on seat is also optional for stainless steel globe valve if being requested by the customer.

Stem Design

The stem is of integral forged design. The minimum diameter of the stem shall per the standard requirement.

Stem Nut

Usually, the stem nut is copper alloy. It is also can be made of ASTM A439 D2 if being requested by the customer. For large sized globe valve, rolling bearing is fitted at the two sides of stem nut in order to minimize the open and close torque of the globe valve.

Special Globe Valve

Besides the common globe valves, we also makes cryogenic globe valve, bellow sealed globe valve, Jacketed globe valve, etc.

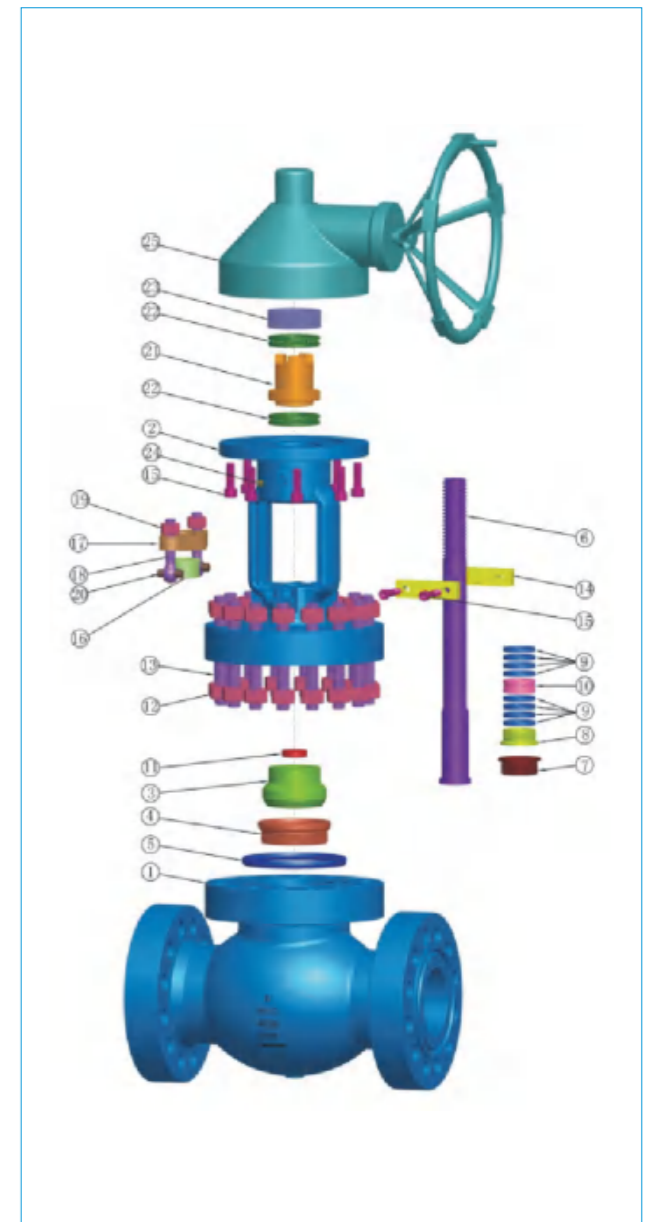

No	Part Name	No	Part Name	No	Part Name
1	Body	10	Lantern Ring	19	Gland Nut
2	Bonnet	11	Thrust Washer	20	Pin
3	Disc	12	Nut	21	Stem Nut
4	Seating Ring	13	Bolt	22	Bearing
5	Gasket	14	Anti-rotating Device	23	Retaining Nut
6	Stem	15	Screw	24	Nipple
7	Disc Nut	16	Gland	25	Bevel gearbox
8	Backseat Bushing	17	Gland Flange		
9	Stem Packing	18	Gland Eyebolt		

API Steel Globe Valve

GENERAL VALVE



API600 Trim material			
Trim code	Seat ring surface	Wedge seat surface	Stem & backseat bushing
1	13Cr	13Cr	A182 F6a
2	18Cr-8Ni	18Cr-8Ni	A182 F304
3	25Cr-20Ni	25Cr-20Ni	A182 F310
4	Hard 13Cr	Hard 13Cr	A182 F6a
5	Stellite	Stellite	A182 F6a
6	13Cr	Cu-Ni Alloy	Monel
7	13Cr	Hard 13Cr	A182 F6a
8	Stellite	13Cr	A182 F6a
9	Cu-Ni Alloy	Cu-Ni Alloy	Monel
10	18Cr-8Ni-Mo	18Cr-8Ni-Mo	A182 F316
11	Cu-Ni Alloy	Cu-Ni Alloy	Monel
12	Stellite	18Cr-8Ni-Mo	A182 F316
13	19Cr-29Ni	19Cr-29Ni	20 Alloy

ASTM Material list of BS1873 Cast Steel Globe Valve

No	Part Name	Carbon Steel to ASTM		Stainless Steel to ASTM				Alloy Steel to ASTM		
		A216 WCB	A352 LCB	A351 CF8	A351 CF8M	A351 CF3	A351 CF3M	A217 WC6	A217 WC9	A217 C5
1	Body	A216 WCB	A352 LCB	A351 CF8	A351 CF8M	A351 CF3	A351 CF3M	A217 WC6	A217 WC9	A217 C5
2	Bonnet	A216 WCB	A352 LCB	A351 CF8	A351 CF8M	A351 CF3	A351 CF3M	A217 WC6	A217 WC9	A217 C5
3	Disc	A216 WCB	A352 LCB	A351 CF8	A351 CF8M	A351 CF3	A351 CF3M	A217 WC6	A217 WC9	A217 C5
4	Seating Ring	A105N	A350LF2	A351 CF8	A351 CF8M	A351 CF3	A351 CF3M	A182 F11	A182 F22	A182 F5
5	Gasket	Graphite+SS304, PTFE								
6	Stem	A182 F6a	A182 F304	A182 F304	A182 F316	A182 F304L	A182 F316L	A182 F304		
7	Disc Nut	A182 F6a	A182 F304	A182 F304	A182 F316	A182 F304L	A182 F316L	A182 F304		
8	Backseat Bushing	A182 F6a	A182 F304	A182 F304	A182 F316	A182 F304L	A182 F316L	A182 F304		
9	Stem Packing	Flexible Graphite								
10	Lantern Ring	A182 F6a	A182 F304	A182 F304	A182 F316	A182 F304L	A182 F316L	A182 F304		
11	Thrust Washer	A182 F6a	A182 F304	A182 F304	A182 F316	A182 F304L	A182 F316L	A182 F304		
12	Nut	A194 2H	A194 4	A194 8				A194 7		
13	Bolt	A193 B7	A320 L7	A193 B8				A193 B16		
14	Anti-rotating Device	ANSI 1020		A182 F304				ANSI 1020		
15	Gland	A194 2H		A194 8				A194 2H		
16	Screw	F6a	A182 F304	A182 F304	A182 F316	A182 F304L	A182 F316L	A182 F304		
17	Gland Flange	A216 WCB	A352 LCB	A351 CF8	A351 CF8	A351 CF8	A351 CF8	A217 WC6	A217 WC9	A217 C5
18	Gland Eyebolt	A193 B7		A193 B8				A193 B16		
19	Gland Nut	A194 2H		A194 8				A194 7		
20	Pin	ANSI 1045		A182 F304				ANSI 1045		
21	Stem Nut	A439 D2/ B148 952A								
22	Bearing	/								
23	Retaining Nut	ANSI 1020								
24	Nipple	Copper Alloy								
25	Bevel gearbox	/								

API Steel Globe Valve

GENERAL VALVE

Construction feature

- Bolted bonnet
- Flat or plug type disc
- Renewable seat (Threaded or welded seat ring)
- ≥10" Thrust bearing design

API598 Pressure Test

- Pressure ratings: Class150
- Hydraulic Shell test: 3.2MPa
- Hydraulic Seat test: 2.2MPa
- Air test: 0.6MPa

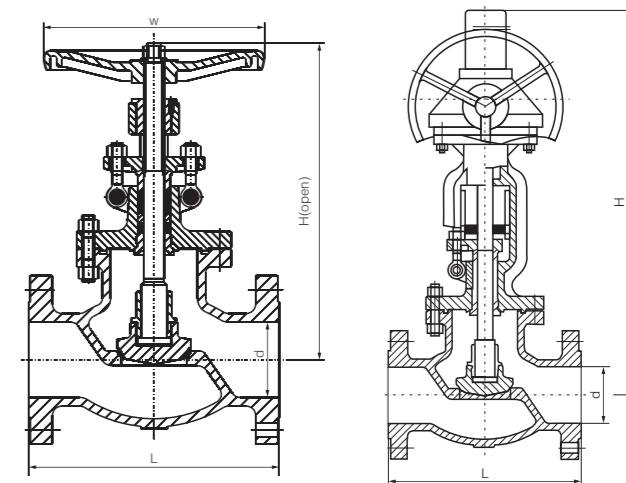

Class	Size		Dimensions (mm)							Weight (Kg)		
	NPS	DN	L			d	H	H1	W	W1	Weight (Kg)	
			RF	RTJ	BW						H.W	G.O
Class 150	2	50	203	216	203	51	330	-	200	-	19	-
	2 1/2	65	216	229	216	64	360	-	250	-	27	-
	3	80	241	254	241	76	390	-	280	-	36	-
	4	100	292	305	292	102	445	-	300	-	53	-
	5	125	356	369	356	127	480	-	350	-	75	-
	6	150	406	419	406	152	520	556	350	310	94	126
	8	200	495	508	495	203	600	658	400	310	148	180
	10	250	622	635	622	254	773	805	450	460	242	291
	12	300	698	711	698	305	880	955	500	460	438	480
	14	350	787	800	787	337	950	1100	600	460	-	600
	16	400	914	927	914	387	996	1175	600	460	-	850
	20	500	978	991	978	488	-	1450	-	600	-	1650
24	600	1295	1308	1295	590	-	1690	-	600	-	2200	

API Steel Globe Valve

GENERAL VALVE

Construction feature

- Bolted bonnet
- Flat or plug type disc
- Renewable seat
(Threaded or welded seat ring)
- ≥ 10" Thrust bearing design

API598 Pressure Test

- Pressure ratings: Class300
- Hydraulic Shell test: 7.8MPa
- Hydraulic Seat test: 5.7MPa
- Air test: 0.6MPa

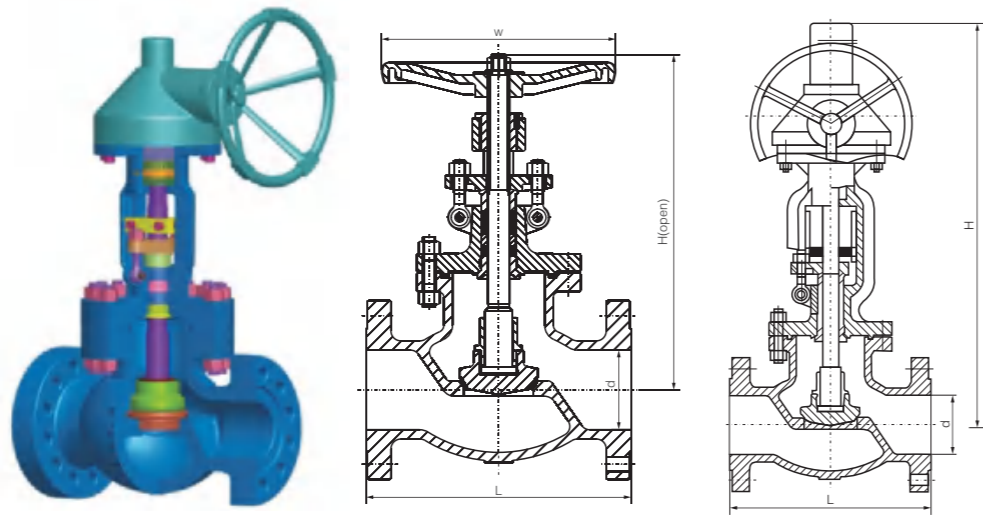

Main size of outside & weight

Class	Size		Dimensions (mm)								Weight (Kg)	
	NPS	DN	L			d	H	H1	W	W1	H.W	G.O
			RF	RTJ	BW							
Class 300	2	50	267	283	267	51	385	-	200	-	25	-
	2 1/2	65	292	308	292	64	420	-	200	-	42	-
	3	80	318	333	318	76	440	-	280	-	46	-
	4	100	356	371	356	102	515	-	350	-	74	-
	5	125	400	416	400	127	580	-	350	-	111	-
	6	150	444	460	444	152	660	690	400	310	165	195
	8	200	559	575	559	203	900	950	550	460	275	327
	10	250	622	638	622	254	950	990	600	460	400	452
	12	300	711	727	711	305	1030	1080	700	460	624	725
	14	350	762	854	762	337	1130	1155	-	600	-	880
16	400	864	879	864	387	1310	1325	-	600	-	1300	
18	450	977	-	977	431	-	1473	-	720	-	1600	
20	500	1016	-	1016	482	-	1574	-	720	-	2100	

API Steel Globe Valve

GENERAL VALVE

Construction feature

- Bolted bonnet
- Flat or plug type disc
- Renewable seat
(Threaded or welded seat ring)
- ≥ 6" Thrust bearing design

API598 Pressure Test

- Pressure ratings: Class600、900
- Hydraulic Shell test: 15.6MPa、23.3MPa
- Hydraulic Seat test: 11.4MPa、17.1MPa
- Air test: 0.6MPa

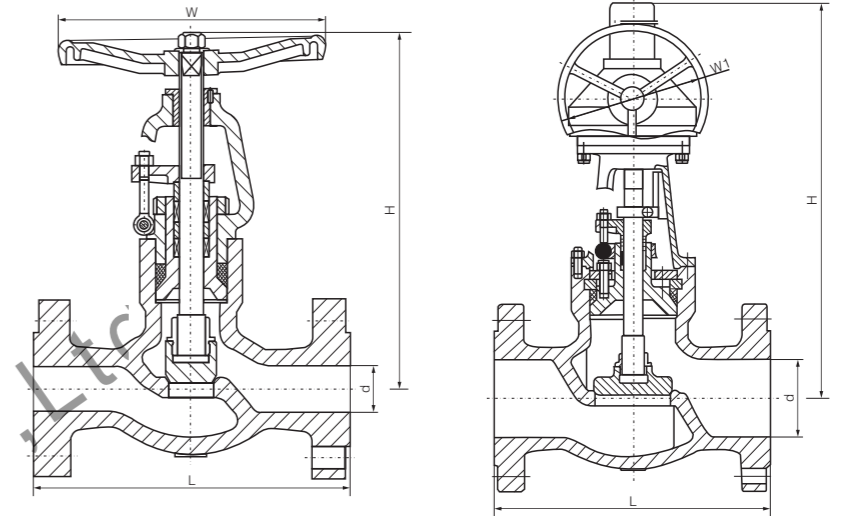

Main size of outside & weight

Class	Size		Dimensions (mm)								Weight (Kg)	
	NPS	DN	L			d	H	H1	W	W1	H.W	G.O
			RF	RTJ	BW							
Class 600	2 1/2	65	330	333	330	64	410	-	280	-	42	-
	3	80	356	359	356	76	465	-	300	-	63	-
	4	100	432	435	432	102	545	575	400	310	107	138
	5	125	508	511	508	127	625	660	500	310	185	215
	6	150	559	562	559	152	785	820	550	460	290	342
	8	200	660	664	660	200	930	960	650	460	540	645
Class 900	2 1/2	65	419	422	419	57	520	-	350	-	68	-
	3	80	381	384	381	73	564	630	400	310	95	128
	4	100	457	460	457	98	685	720	450	310	160	210
	5	125	559	562	559	121	780	840	550	460	270	325
	6	150	610	613	610	146	950	1015	650	460	410	480
	8	200	660	664	660	200	930	960	650	460	540	645
Class	DN		RTJ									
	mm	in	L	D	D1	D2	b	n-φd	H	DO		
Class 1500	65	2 1/2	422	244	190.5	108.0	49.0	8-φ28.5	461	400		
	80	3	473	267	203.2	136.5	55.7	8-φ32	554	450		
	100	4	549	311	241.3	161.9	61.8	8-φ35	639	500		
	125	5	676	375	292.1	193.7	81.1	8-φ41	780	560		
	150	6	711	394	317.5	211.1	92.1	12-φ38	904	630		
	200	8	841	483	393.7	269.9	103.0	12-φ44.5	1140	680		

Steel Check Valve General Valve

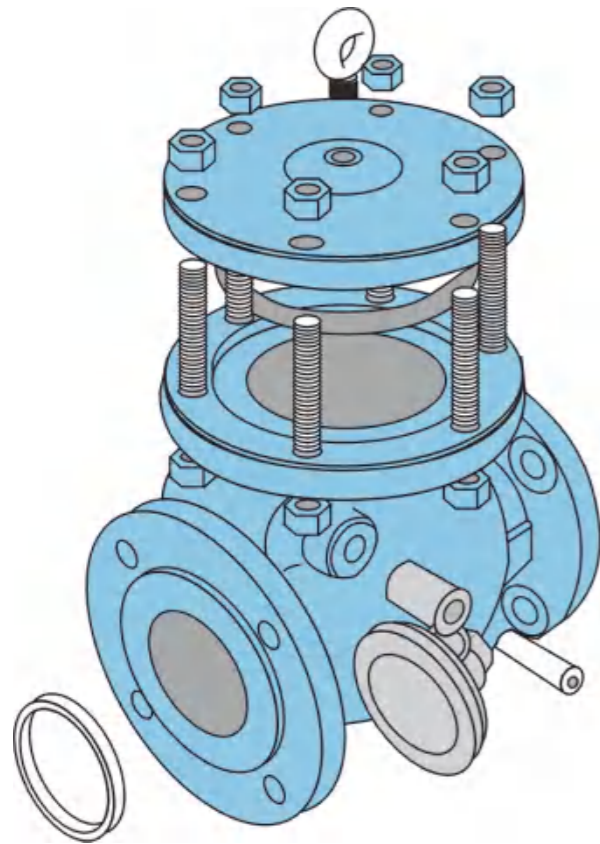

Reliable seat seal

Design and Manufacture: Cast steel check valve to BS1868, ASME B16.34 and API 6D;
 Forged steel check valve to API 602.
 Inspection and Test: API 598 or API 6D.
 End flange dimension: ASME B16.5 (for NPS ≤ 24) ;
 ASME B 16.47 series B, API 605 or ASME B16.47 series A, MSS SP-44 (for NPS > 24) .
 BW end dimension: ASME B16.25.
 Socket-weld dimension: ASME B16.11.
 Face to face and end to end: ASME B16.10.
 Pressure-temperature ratings: ASME B16.34.
 Wall thickness dimension: API 600 and BS 1868.

Seat

For carbon steel check valve, the seat is usually forged Steel. The sealing surface of the seat is spray welded with hard alloy Specified by the customer. Renewable threaded seat is used for NPS ≤ 10 check valves, and welded on seat can be also optional if being requested by the customer. Welded on seat is used for NPS ≥ 12 carbon steel check valves. For stainless steel check Valve, integral seat is usually adopted, or to weld hard alloy directly integrally. Threaded or welded on seat is also optional for stainless steel check valve if being requested by the customer.

The features of check valve

Bolted Bonnet;
 Swing and lift disc;
 Metallic seating surfaces.

Body-To-Bonnet Joint

Stainless steel + flexible graphite wounded gasket is used for Class150 and Class300 check valve; Stainless steel + flexible graphite wounded gasket is used for Class600 check valve, and joint gasket is also optional for Class600 check valve; Ring joint gasket is used for Class900 check valve; Pressure seal design is used for Class1500 ~ Class2500 check valves.

Body and Bonnet Connection

The body and bonnet of Class150 ~ Class900 check valves are usually with studs and nuts. And the body and bonnet of Class1500 ~ Class2500 check valves are usually of pressure seal design.

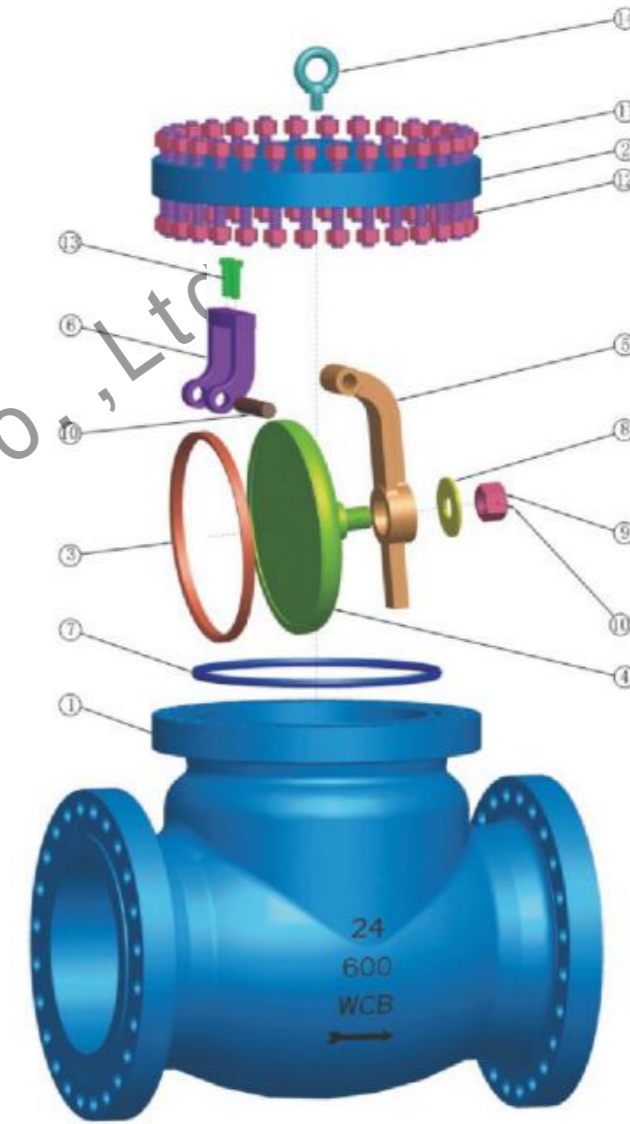

No	Part Name	No	Part Name	No	Part Name
1	Body	6	Yoke	11	Nut
2	Cover	7	Gasket	12	Bolt
3	Seat Ring	8	Disc Washer	13	Screw
4	Disc	9	Disc Nut	14	Lifting Lug
5	Hinge	10	Pin		

API Steel Check Valve

GENERAL VALVE



○ API600 Trim material

Trim code	Seat ring surface	Wedge seat surface	Hinge Pin
1	13Cr	13Cr	A182 F6a
2	18Cr-8Ni	18Cr-8Ni	A182 F304
3	25Cr-20Ni	25Cr-20Ni	A182 F310
4	Hard 13Cr	Hard 13Cr	A182 F6a
5	Stellite	Stellite	A182 F6a
6	13Cr	Cu-Ni Alloy	Monel
7	13Cr	Hard 13Cr	A182 F6a
8	Stellite	13Cr	A182 F6a
9	Cu-Ni Alloy	Cu-Ni Alloy	Monel
10	18Cr-8Ni-Mo	18Cr-8Ni-Mo	A182 F316
11	Cu-Ni Alloy	Cu-Ni Alloy	Monel
12	Stellite	18Cr-8Ni-Mo	A182 F316
13	19Cr-29Ni	19Cr-29Ni	20 Alloy

ASTM Material list of BS1868 Swing Check Valve

No.	Part name	Carbon Steel to ASTM		Stainless Steel to ASTM				Alloy Steel to ASTM		
		A216 WCB	A352 LCB	A351 CF8	A351 CF8M	A351 CF3	A351 CF3M	A217 WC6	A217 WC9	A217 C5
1	Body	A216 WCB	A352 LCB	A351 CF8	A351 CF8M	A351 CF3	A351 CF3M	A217 WC6	A217 WC9	A217 C5
2	Cover	A216 WCB	A352 LCB	A351 CF8	A351 CF8M	A351 CF3	A351 CF3M	A217 WC6	A217 WC9	A217 C5
3	Seat Ring	A105N	A352 LF2	A351 CF8	A351 CF8M	A351 CF3	A351 CF3M	A182 F11	A182 F22	A182 F5
4	Disc	A216 WCB	A352 LCB	A351 CF8	A351 CF8M	A351 CF3	A351 CF3M	A217 WC6	A217 WC9	A217 C5
5	Hinge	A216 WCB	A352 LCB	A351 CF8	A351 CF8M	A351 CF3	A351 CF3M	A217 WC6	A217 WC9	A217 C5
6	Yoke	A216 WCB	A352 LCB	A351 CF8	A351 CF8M	A351 CF3	A351 CF3M	A217 WC6	A217 WC9	A217 C5
7	Gasket	Graphite, SS304, PTFE								
8	Disc Washer	A182 F6a	A182 F6a	A182 F304	A182 F316	A182 F304L	A182 F316L	A182 F304		
9	Disc Nut	A182 F6a	A182 F304	A182 F304	A182 F316	A182 F304L	A182 F316L	A182 F304		
10	Pin	A182 F6a	A182 F304	A182 F304	A182 F316	A182 F304L	A182 F316L	A182 F304		
11	Nut	A194 2H	A194 4	A194 8				A194 7		
12	Bolt	A193 B7	A320 L7	A193 B8				A193 B16		
13	Screw	193 B7	A320 L7	A182 F304	A182 F316	A182 F304L	A182 F316L	A193 B16		
14	Lifting Lug	A194 2H								

※ Suitable for H₂S service and meet requirement of NACE MR 0175.

API Steel Swing Check Valve

GENERAL VALVE

Construction feature

Bolted cover
Renewable seat
(Threaded or welded seat ring)

API598 Pressure Test

Pressure ratings: Class150, Class300
Hydraulic Shell test: 3.2MPa, 7.8MPa
Hydraulic Seat test: 2.2MPa, 5.7MPa
Air test: 0.6MPa

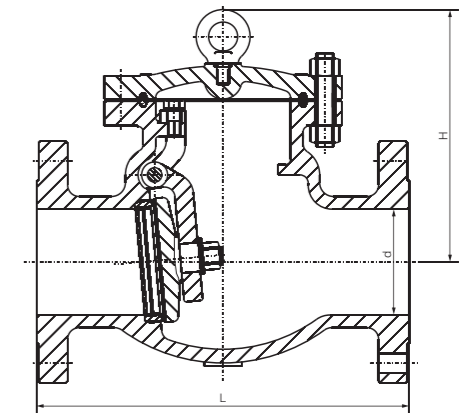

Main size of outside & weight

Size	NPS	DN	Class 150					Class 300						
			L			d	H	Weight (Kg)	L			d	H	Weight (Kg)
			RF	RTJ	BW				RF	RTJ	BW			
2	50	203	216	203	51	132	15	267	283	267	51	144	20	
2 1/2	65	216	229	216	64	147	20	292	308	292	64	169	35	
3	80	241	254	241	76	176	27	318	333	318	76	210	40	
4	100	292	305	292	102	198	45	356	371	356	102	260	61	
5	125	330	343	330	127	255	58	400	416	400	127	295	80	
6	150	356	368	356	152	320	69	445	460	445	152	326	130	
8	200	495	508	495	203	380	131	533	549	533	203	380	190	
10	250	622	635	622	254	440	219	622	638	622	254	440	296	
12	300	699	711	699	305	480	321	711	727	711	305	520	450	
14	350	787	800	787	337	530	380	838	854	838	337	540	640	
16	400	864	876	864	387	580	560	864	879	864	387	588	850	
18	450	978	991	978	438	618	630	978	994	978	432	670	1030	
20	500	978	991	978	489	657	770	1016	1035	1016	483	720	1330	
24	600	1295	1308	1295	591	760	960	1346	1368	1346	584	850	1950	
26	650	1295	-	1295	633	840	1250	1346	1372	1346	633	920	2300	
28	700	1448	-	1448	684	920	1580	1499	1524	1499	684	1150	2600	
30	750	1524	1537	1524	735	980	1950	1594	1619	1594	735	1260	3200	
32	800	1727	-	1727	779	1016	2800	1727	-	1727	779	1380	3700	
36	900	1956	1969	1956	874	1092	3200	2083	-	2083	874	1540	4300	

API Steel Swing Check Valve

GENERAL VALVE

Construction feature

Bolted cover
Renewable seat
(Threaded or welded seat ring)

API598 Pressure Test

Pressure ratings: Class600、900、1500、2500
Hydraulic Shell test: 15.6MPa、23.3MPa、38.8MPa、63.8MPa
Hydraulic Seat test: 11.4MPa、17.1MPa、28.5MPa、46.9MPa
Air test: 0.6MPa

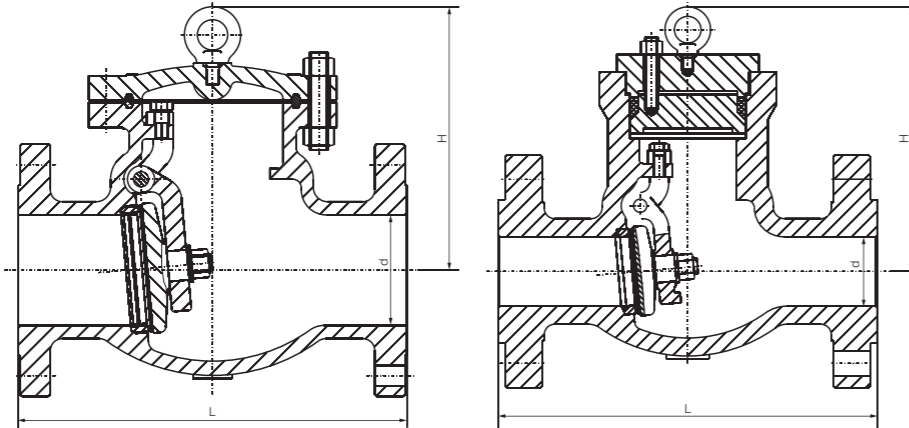

Main size of outside & weight

Size	Class 600							Class 900						
	NPS	DN	L			d	H	Weight (Kg)	L			d	H	Weight (Kg)
			RF	RTJ	BW				RF	RTJ	BW			
2	50	292	295	292	51	170	28	368	371	368	47	200	48	
2 1/2	65	330	333	330	64	178	40	419	422	419	57	220	75	
3	80	356	359	356	76	246	68	381	384	381	73	280	95	
4	100	432	435	432	102	290	117	457	460	457	98	320	135	
5	125	508	511	508	127	320	155	559	562	559	121	360	200	
6	150	559	562	559	152	360	192	610	613	610	146	400	264	
8	200	660	664	660	200	430	340	737	740	737	190	460	424	
10	250	787	791	787	248	502	515	838	841	838	284	560	730	
12	300	838	841	838	298	554	750	965	968	965	282	632	1070	
14	350	889	892	889	327	595	890	1029	1038	1029	311	680	1180	
16	400	991	994	991	375	680	1303	1130	1140	1130	354	780	1790	
18	450	1092	1095	1092	419	778	1800	1219	1232	1219	400	880	2500	
20	500	1194	1200	1194	464	970	2150	1321	1334	1321	444	1050	3080	
24	600	1397	1407	1397	559	1100	3200	1549	1568	1549	533	1200	4600	

Size	Class 1500							Class 2500						
	NPS	DN	L			d	H	Weight (Kg)	L			d	H	Weight (Kg)
			RF	RTJ	BW				RF	RTJ	BW			
2	50	368	371	368	47	210	48	451	454	451	35	230	68	
2 1/2	65	419	422	419	57	240	75	508	514	508	47	260	100	
3	80	470	473	470	70	303	120	578	584	578	57	330	165	
4	100	546	549	546	92	340	180	673	683	673	73	370	260	
5	125	673	676	673	111	380	294	794	807	794	92	410	440	
6	150	705	711	705	136	430	385	914	927	914	111	460	580	
8	200	832	841	832	174	500	634	1022	1038	1022	146	530	970	
10	250	991	1000	991	222	590	1140	1270	1292	1270	184	620	1700	
12	300	1130	1146	1130	263	660	1650	1422	1445	1422	219	690	2600	
14	350	1257	1276	1257	289	710	2000	-	-	-	-	-	-	
16	400	1384	1407	1384	330	820	2700	-	-	-	-	-	-	

API Steel Lift Check Valve

GENERAL VALVE

Construction feature

Bolted cover
Renewable seat
(Threaded or welded seat ring)

API598 Pressure Test

Pressure ratings: Class150、300、Class600、900
Hydraulic Shell test: 3.2MPa、7.8MPa、15.6MPa、23.3MPa
Hydraulic Seat test: 2.2MPa、5.7MPa、11.4MPa、17.1MPa
Air test: 0.6MPa

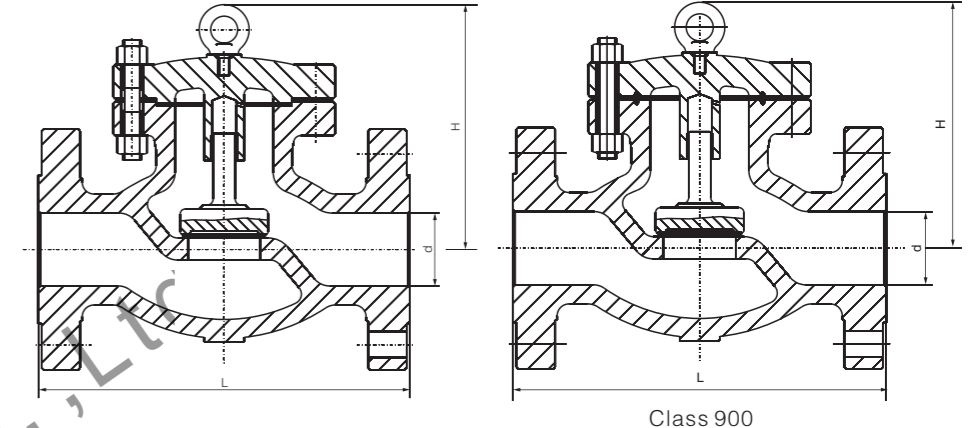

Main size of outside & weight

Size	Class 150							Class 300						
	NPS	DN	L			d	H	Weight (Kg)	L			d	H	Weight (Kg)
			RF	RTJ	BW				RF	RTJ	BW			
1/2	15	108	119	108	13	76	3	152	162	152	13	78	5	
3/4	20	117	130	117	19	76	4	178	191	178	19	82	6	
1	25	127	140	127	25	98	5	203	216	203	25	102	8	
1 1/4	32	140	153	140	32	102	7	216	229	216	32	106	11	
1 1/2	40	165	178	165	38	115	8	229	242	229	38	118	13	
2	50	203	216	203	51	140	15	267	283	267	51	140	26	
2 1/2	65	216	229	216	64	162	22	292	308	292	64	164	33	
3	80	241	254	241	76	168	28	318	333	318	76	178	50	
4	100	292	305	292	102	194	42	356	371	356	102	195	86	
5	125	356	368	356	127	210	60	400	416	400	127	223	120	
6	150	406	419	406	152	226	75	445	460	445	152	245	180	
8	200	495	508	495	203	250	118	533	549	533	203	280	220	
10	250	622	635	622	254	275	194	622	638	622	254	336	310	
12	300	699	711	699	305	332	320	711	727	711	305	380	510	

Size	Class600							Class900						
	NPS	DN	L			d	H	Weight (Kg)	L			d	H	Weight (Kg)
			RF	RTJ	BW				RF	RTJ	BW			
2	50	292	295	292	51	152	32	368	371	368	47	180	50	
2 1/2	65	330	333	330	64	167	45	419	422	419	57	200	65	
3	80	356	359	356	76	178	68	381	384	381	73	235	88	
4	100	432	435	432	102	215	98	457	460	457	98	270	140	
5	125	508	511	508	127	240	155	559	562	559	121	300	210	
6	150	559	562	559	152	279	230	610	613	610	146	350	300	
8	200	660	664	660	200	328	300	737	740	737	190	400	390	

Floating Ball Valve

General Valve

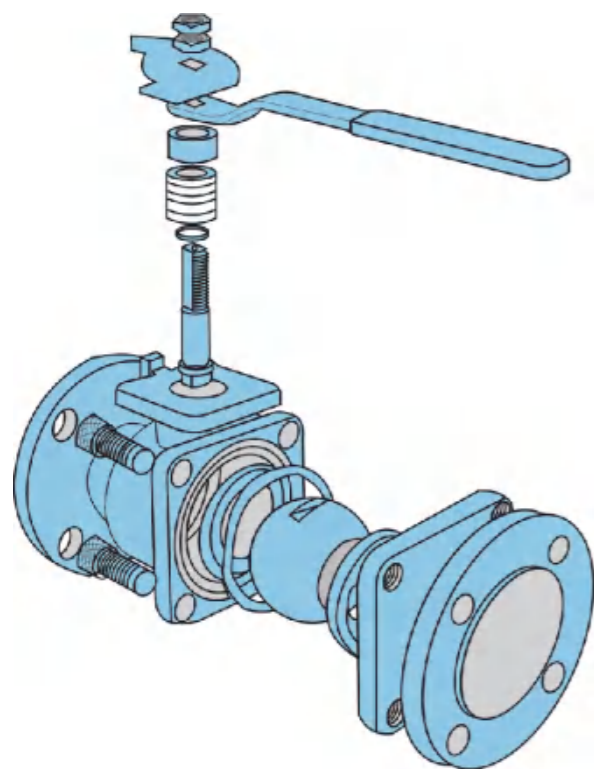

Standards

Design and Manufacture: API 6D, BS5351, ASME B16.34
 API 608, MSS-SP-72
 Face To Face Dimension: ASME B16.10
 Flange Connection Dimension: ASME B16.5
 BW Connection Dimension: ASME B16.25
 Test And Inspection: API 598
 Fire-safe Design: API 607/6FA
 Anti-static Design&anti Blow-out Stem

Application

Floating ball valves are suitable for various kinds of pipelines of Class 150 to Class 1500, to turn on or off the pipeline medium, of which the operation types include manual, worm gear and pneumatic or electric actuators.

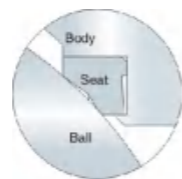

At lower medium pressure

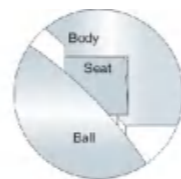

At higher medium pressure

Reliable seat seal

The structure design of elastic sealing ring has been adopted for floating ball valves. This seat design features a bigger sealing pressure ratio between the ring surface and the ball when medium pressure gets lower, where the contacting area is smaller. Thus, the reliable seal is ensured. When the medium pressure gets higher, the contacting area between seat ring and ball becomes bigger as the sealing ring transforms elastically to undertake the bigger force pushed by the medium without any damage.

Anti-static feature

The traditional packing flange design has been improved to be of two piece structure, i.e., being as a packing flange plate and a follower, the latter contacts the flange plate with spherical surface. Thus, the follower remains vertical always, and is lined internally with a PTFE bush to prevent the galling against and friction between the stem, which can also reduce the operation torque of the valve.

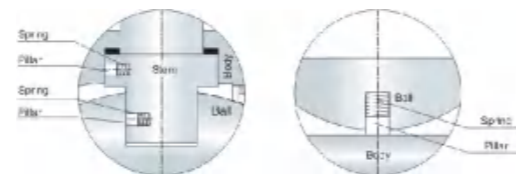

Anti-Static design for ball valve ∅32mm Anti-Static design for ball valve ∅25mm

Fire safe design

With the valve heated in a fire application, the non-metal material parts such as seat sealing ring of PTFE, stem back seat gasket, gland packing, and the sealing gasket between body and bonnet might disintegrate or be damaged due to high temperature. Our company specially designed structure of auxiliary metal to metal seal is provided to effectively prevent both internal and external leakage of the valve. As required by customers, Our company floating ball valves with design can meet the requirement of API 607, API 6FA, BS 6755.



Fire safe design of valve body and bonnet flanges

Based on customers' requirement, a packing tightening design may be employed to obtain more reliable stem packing seal, which is loaded by bevelling spring.

The traditional packing flange design has been improved to be of two piece structure, i.e., being as a gland flange and gland, the latter contacts the gland flange with spherical surface. Thus, the gland remains vertical always, and is lined internally with a PTFE bush to prevent the galling against and friction between the stem, which can also reduce the operation torque of the valve.

Mounting pad provided

Our company has provided for floating ball valve with a mounting pad, through which it is easy to fix the actuators, such as worm gear, pneumatic and electric actuators.

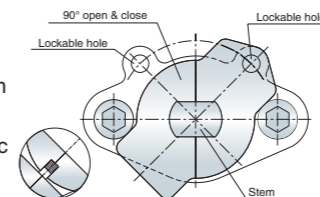

Reliable stem seal

The blow-out proof design has been adopted for the stem to ensure that even if the pressure in the body cavity is risen accidentally and the packing flange becomes invalid, the stem may not be blown out by medium. The stem features the design with a backseat, being assembled from underneath. The sealing force against the backseat gets higher as the medium pressure becomes higher. So the reliable seal of the stem can be assured under variable medium pressure.



Stem assembled from underneath may not be blown out by medium

Stem assembled downward may be blown out

V type packing structure has been employed to effectively transform the pushing force of the gland flange and the medium pressure into the sealing force against the stem.

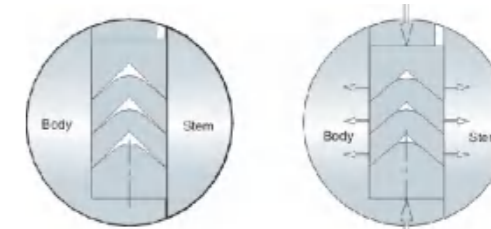

Packing before pressed

Packing after pressed

Wrong operation prevention

To prevent the ball valve from wrong operation, the keylock with 90° of open and close positioning pad has been provided, which can be lockable as required. At the stem head, where the lever fixes, a flat is designed so that the valve opens with the lever in parallel to piping, and with the lever right-angled to the piping, the valve is closed. So, it is ensured that the valve indicator of open and close can never make mistake.



API Floating Ball Valve

GENERAL VALVE

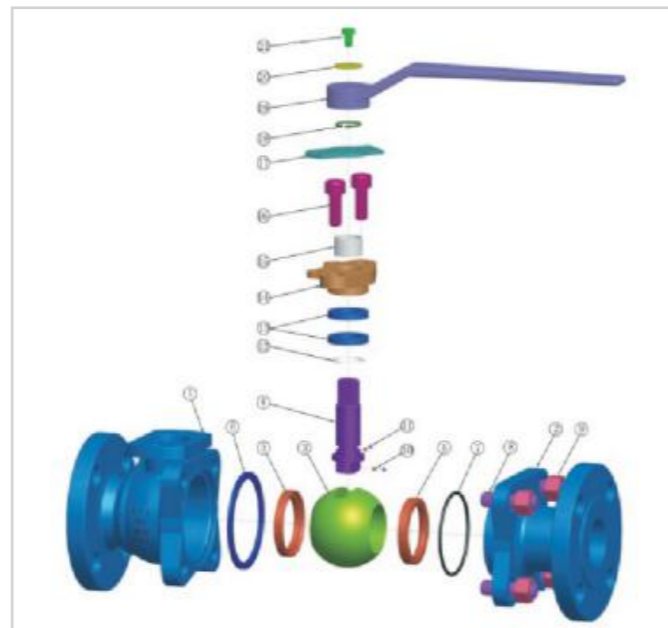

ASTM Material list of floating ball valve

No	Part Name	Carbon Steel to ASTM		Stainless Steel to ASTM			
1	Body	A216 WCB	A352 LCB	A351 CF8	A351 CF8M	A351 CF3	A351 CF3M
2	Bonnet	A216 WCB	A352 LCB	A351 CF8	A351 CF8M	A351 CF3	A351 CF3M
3	Ball	A351 CF8	A352 LCB	A351 CF8	A351 CF8M	A351 CF3	A351 CF3M
4	Stem	A182 F6a	A182 F304	A182 F304	A182 F316	A182 F304L	A182 F316L
5	Seat ring	PTFE, RTFE, PEEK, DELRIN					
6	Gasket	Graphite+SS304, PTFE					
7	O-ring	Fluororubber					
8	Bolt	A193 B7/B7M	A193 L7/L7M	A193 B8/B8M			
9	Nut	A194 2H/2HM	A194 4/4M	194 B8M			
10	Small spring	SS304					
11	Small ball	SS304					
12	Thrust washer	PTFE					
13	Stem packing	Flexible Graphite/PTFE					
14	Packing gland	A216 WCB	A352 LCB	A351 CF8	A351 CF8M	A351 CF3	A351 CF8M
15	Shaft sleeve	PTFE					
16	Screw	A193 B7	A320 L7	A193 B8/B8M			
17	Positioning plate	Galvanized Steel					
18	Retaining ring	Carbon Steel					
19	Lever	Carbon Steel					
20	Gasket	Carbon Steel					
21	Screw	Carbon Steel					

API Floating Ball Valve

GENERAL VALVE

Construction feature

- Close joint and no leakage at middle flange
- Anti-static and blow-out proof stem
- Fire-safe design Split body
- Locking device ISO5211 mounting pad

API598 Pressure Test

- Pressure ratings: Class150
- Hydraulic Shell test: 3.2MPa
- Hydraulic Seat test: 2.2MPa
- Air test: 0.6MPa

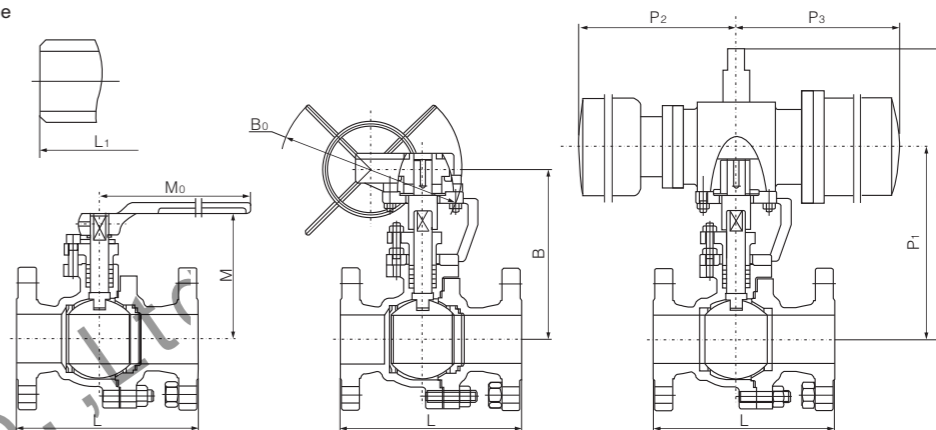

Main size of outside & weight

Pressure	Nominal diameter		Flange	Butt welding	Hand-operated		Worm gear		Air driving and hydraulic driving				Electric driving			Weight (Kg)	
	mm	in	L	L1	M	M0	B	B0	P	P1	P2	P3	H	H1	H0	RF	BW
Class 150	15	1/2	108	140	59	130	-	-	200	122	326	136	-	-	-	2.3	2
	20	3/4	117	152	63	130	-	-	204	126	326	136	-	-	-	3	2.5
	25	1	127	165	75	160	-	-	257	162	347	181	-	-	-	4.5	3.8
	32	1 1/4	140	178	95	230	-	-	245	169	420	181	-	-	-	5.2	4.3
	40	1 1/2	165	190.5	95	230	-	-	264	169	420	181	-	-	-	7	5.8
	50	2	178	216	107	230	-	-	340	209	426	257	472	377	190	15	12
	65	2 1/2	191	241	142	400	-	-	370	239	426	257	486	391	190	20	17
	80	3	203	283	152	400	-	-	389	258	490	257	579	484	190	25	21
	100	4	229	305	178	650	-	-	594	337	523	287	595	500	190	40	36
	125	5	356	381	252	1050	-	-	646	437	378	378	650	500	400	68	52
	150	6	394	457	272	1050	292	400	646	437	378	378	739	589	400	97	93
200	8	457	521	342	1410	398	600	781	537	530	530	799	649	400	160	154	

API Floating Ball Valve

GENERAL VALVE

Construction feature

Close joint and no leakage at middle flange
 Anti-static and blow-out proof stem
 Fire-safe design Split body
 Locking device ISO5211 mounting pad

API598 Pressure Test

Pressure ratings: Class300
 Hydraulic test: 7.8MPa
 Hydraulic test: 5.7MPa
 Air test: 0.6MPa

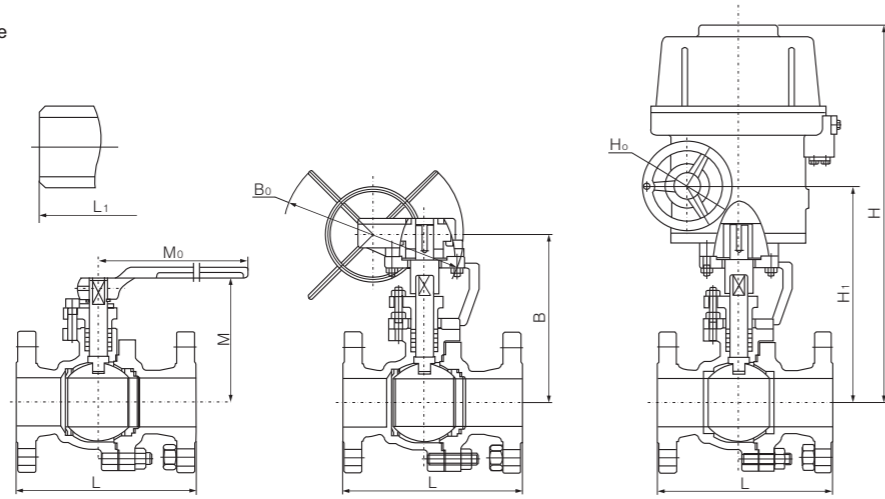

Main size of outside & weight

Pressure	Nominal diameter		Flange	Butt welding	Hand-operated		Worm gear		Air driving and hydraulic driving				Electric driving			Weight (Kg)	
	mm	in	L	L ₁	M	M ₀	B	B ₀	P	P ₁	P ₂	P ₃	H	H ₁	H ₀	RF	BW
Class 300	15	1/2	140	140	59	130	-	-	200	122	326	136	-	-	-	2.5	2.1
	20	3/4	152	152	63	130	-	-	204	126	326	136	-	-	-	3.5	3
	25	1	165	165	75	160	-	-	257	162	347	181	-	-	-	5.5	4.8
	32	1 1/4	178	178	95	230	-	-	245	169	420	181	-	-	-	7.6	5.9
	40	1 1/2	190.5	190.5	95	230	-	-	264	169	420	181	-	-	-	10.5	8.7
	50	2	216	216	107	230	-	-	340	209	426	257	472	377	190	20	17
	65	2 1/2	241	241	142	400	-	-	379	248	426	257	486	391	190	25	22
	80	3	283	283	152	400	-	-	452	295	490	257	579	484	190	31	28
	100	4	305	305	178	650	-	-	594	375	523	287	595	500	190	52	48
	125	5	381	381	252	1050	-	-	646	437	378	378	650	500	400	78	71
150	6	403	403	272	1050	292	400	744	500	378	378	739	589	400	118	105	
200	8	502	521	342	1410	398	600	920	615	530	530	799	649	400	-	-	

Email: jameschen324@gmail.com
 Super Flange & Pipe Fittings Co., Ltd.

API Floating Ball Valve

GENERAL VALVE

Construction feature

Close joint and no leakage at middle flange
 Anti-static and blow-out proof stem
 Fire-safe design Split body
 Locking device ISO5211 mounting pad

API598 Pressure Test

Pressure ratings: Class600
 Hydraulic test: 15.6MPa
 Hydraulic test: 11.4MPa
 Air test: 0.6MPa

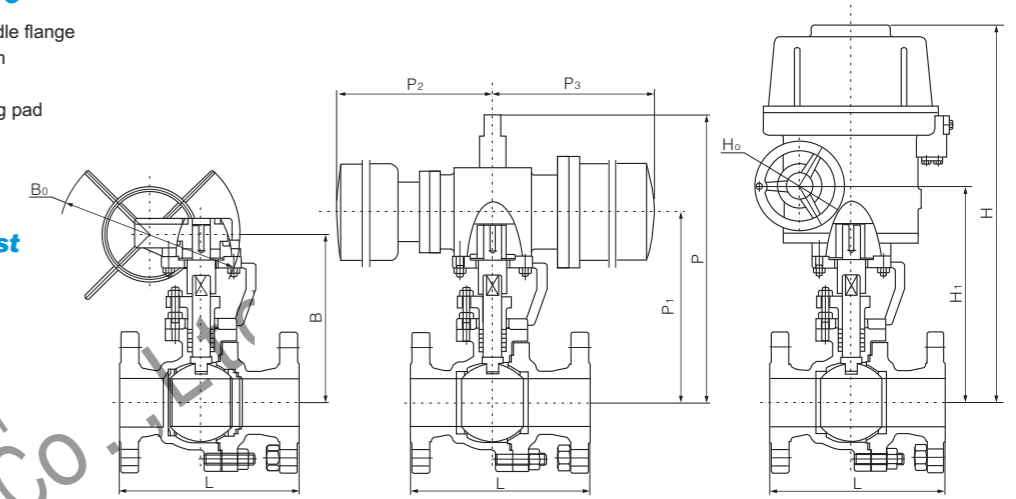

Main size of outside & weight

Pressure	Nominal diameter		Flange	Butt welding	Hand-operated		Worm gear		Air driving and hydraulic driving				Electric driving			Weight (Kg)	
	mm	in	L	L ₁	M	M ₀	B	B ₀	P	P ₁	P ₂	P ₃	H	H ₁	H ₀	RF	BW
Class 600	15	1/2	165	165	59	160	-	-	200	122	326	136	-	-	-	7.5	6
	20	3/4	190.5	190.5	63	160	-	-	204	126	326	136	-	-	-	10.5	8.7
	25	1	216	216	75	230	-	-	257	162	347	181	-	-	-	14.5	11
	32	1 1/4	178	178	95	230	-	-	245	169	420	181	-	-	-	16.1	13.1
	40	1 1/2	241	241	95	400	-	-	264	169	420	181	-	-	-	18.5	14.7
	50	2	292	292	167	400	-	-	340	209	426	257	472	377	400	38	31
	65	2 1/2	330	330	180	650	-	-	379	248	426	257	599	449	400	56	49
	80	3	356	356	198	650	292	400	452	295	490	257	599	449	400	66	58
	100	4	432	432	198	1050	398	600	594	375	378	378	632	472	400	76	68
	150	6	559	559	-	-	400	800	650	425	378	378	650	430	400	-	-
200	8	660	660	-	-	430	800	680	485	530	530	710	490	400	-	-	

Trunnion Ball Valve General Valve

Standards

Design and Manufacture: API 6D, BS5351, ASME B16.34
API 608, MSS-SP-72
Face To Face Dimension: ASME B16.10
End flange dimension: ASME B16.5(for NPS≤24); ASME B16.47 series B, API 605 or ASME B16.47 series A, MSS SP-44(for NPS>24).
BW Connection Dimension: ASME B16.25
Test And Inspection: API 598
Fire-safe Design: API 607/6FA
Anti-static Design&anti Blow-out Stem

Urgent grease injection device

According to customers' requirement, the trunnion ball valves made by Our company are provided with devices for urgent grease injection, which are on both the stem and seat for the trunnion ball valves of DN>150mm (NPS6), and in the body cavity for the valve of DN<125mm. When the O ring of stem or the body seat ring is damaged due to accident, the medium leakage between body and stem can be prevented by injecting the sealing grease through the device.

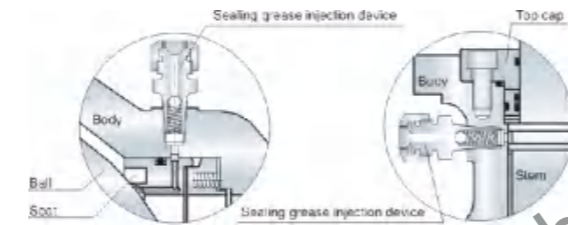

Double-block and bleed functions

In our company, trunnion ball valve features the front ball sealing design structure. Each seat of the ball valve can separately cut off the medium at both inlet and outlet of the valve to realize double-block functions. When the ball valve is closed, body cavity and two of the body ends can be blocked with each other even if both the inlet and outlet are under pressure, when the medium left in the body cavity might be bled through the relief valve.

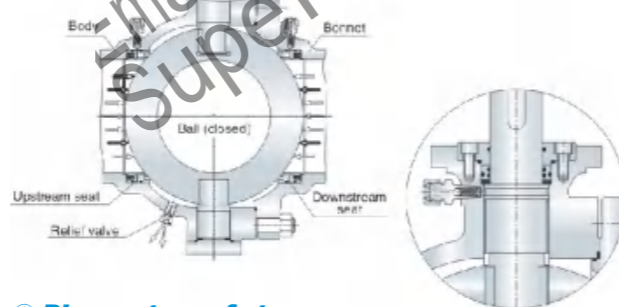

Blow-out proof stem

Blow-out proof structure is provided with for the stem, which is positioned by the up-end cap and screw, being guaranteed not to be blown-out by the medium even if at abnormal risen pressure in the cavity.

Anti-static design

The ball of the trunnion ball valve gets close contact with each other through the trunnion, adjusting cushion, and down-end cap, the passage of static electricity thus forms together with the valve, which may lead the static electricity caused by sparks generated by friction between the ball and seat during on and off performance to the ground to prevent the possible risk of fire or explosion.

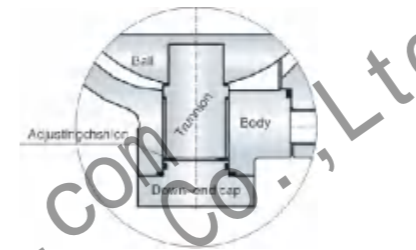

The Bi-sealing design structure, i.e. seat sealing in front of the ball and seat sealing behind the ball

According to some special working conditions and customers' requirement, We has provided the trunnion ball valve with the Bi-sealing design structure, i.e. seat sealing in front of the ball and seat sealing behind the ball, thus the reliable sealing of the valve is ensured because the valve can perform normally even if one of the effective sealing designs becomes lost due to the abnormal condition.

Regarding the seat in front of the ball, the piston effect formed by the area difference between D1 and D2 ,plus the pre-tightened force of a spring would cause the seat in front of the ball by the pressure difference of the medium before and after the valve to touch the ball closely to form the tightness, of which the sealing force will become bigger as the pressure difference gets higher.

Regarding the seat after the ball, the piston effect formed by the area difference between D2 and D3 ,plus the pretig-htened force of a spring would cause the seat behind the ball to touch the ball closely to form the tightness, of which the sealing force will become bigger as the pressure difference gets higher.

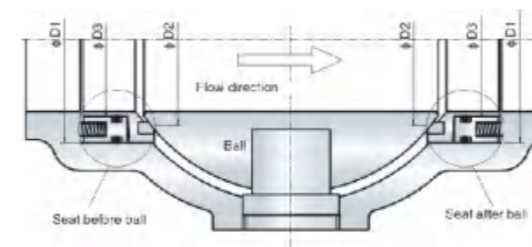

Self-relief in the body cavity

As the liquid medium left in the body cavity gasifies due to increased temperature, the pressure in the body cavity becomes abnormally higher when the medium itself in the cavity would propel the seat and self-relieves the pressure to ensure the safety of valve.

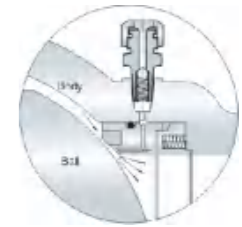

Fire safe design

With the valve heated in a fire application, the non-metal material parts such as seat sealing ring of PTFE, O ring for the stem, and sealing gasket for body and bonnet, might be damaged due to high temperature. Our company special design of auxiliary metal to metal or the graphite seal is provided for the trunnion ball valve to effectively prevent both internal and external leakage of the valve. As required by customers, Our company fire safe design for the trunnion ball valve meets the requirement of API 607, API 6Fa, BS 6755.

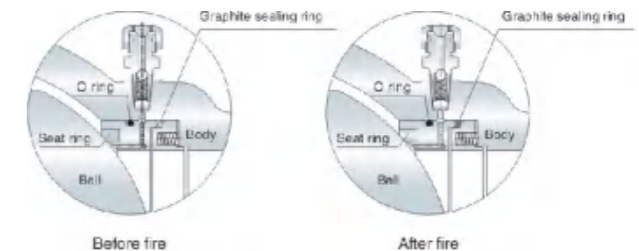

Fire safe design of seat

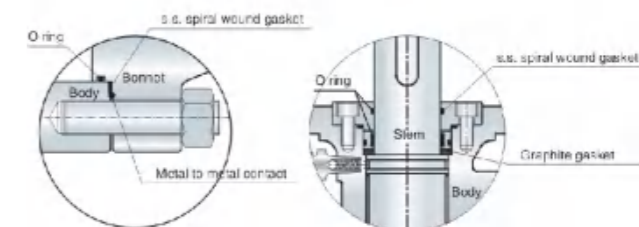

Fire safe design of valve body and bonnet flanges

Fire safe design of stem

Mounting pad provided

Our company has provided for trunnion ball valve with a mounting pad for fixing the actuators, such as worm gear, pneumatic, electric, hydraulic, and pneumatic & hydraulic actuators.

API Trunnion Ball Valve

GENERAL VALVE

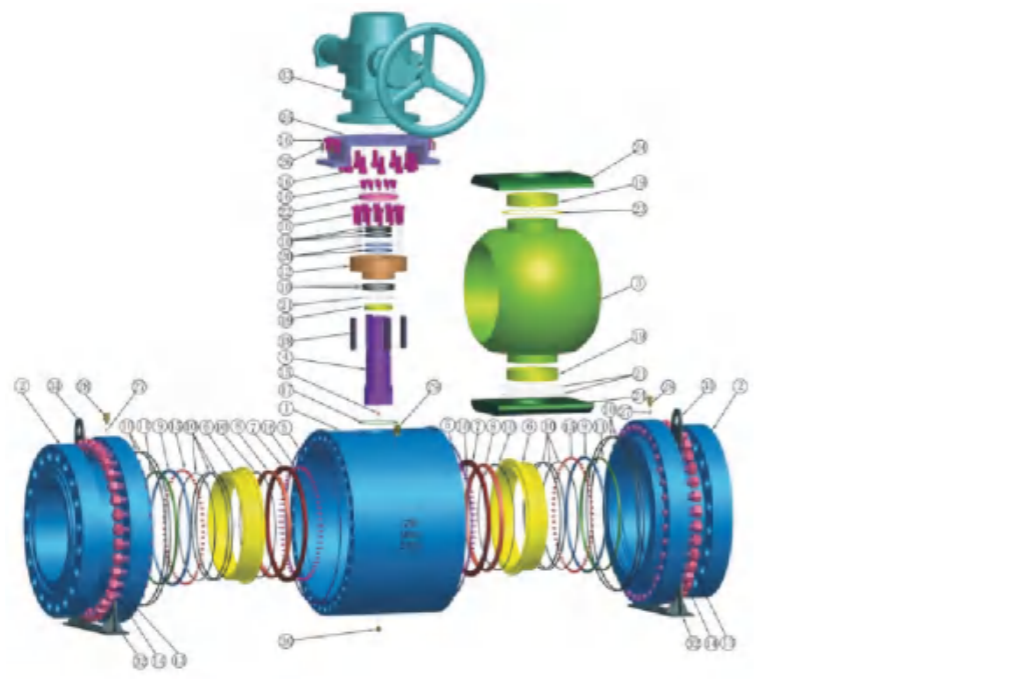

ASTM Material list of cast steel trunnion mounted ball valve

No	Part Name	Carbon Steel to ASTM		Stainless Steel to ASTM				
1	Body	ASTM A105N	A350 LF2	A182 F304	A182 F316	A182 F304L	A182 F316L	A182 F51
2	Bonnet	ASTM A105N	A350 LF2	A182 F304	A182 F3316	A182 F304L	A182 F316L	A182 F51
3	Ball	A351 CF8	A351 CF8	A351 CF8	A351 CF8M	A351 CF3	A351 CF3M	OD4MCU
4	Stem	A182 F6a	A182 F304	A182 F304	A182 F316	A182 F304L	A182 F316L	A182 F51
5	Gasket	SS304 +Graphite, PDFE						
6	Seat	A105N+ENP	LF2+ENP	A182 F304	A182 F316	A182 F304L	A182 F316L	A182 F51
7	Clamping ring	A105N+ENP	LF2+ENP	A182 F304	A182 F316	A182 F304L	A182 F316L	A182 F51
8	Seat ring	PTFE, RTFE, PEEK, DELRIN						
9	Seat back	A105N+ENP	LF2+ENP	A182 F304	A182 F316	A182 F304L	A182 F316L	A182 F51
10	O-ring	Fluororubber						
11	Seat gasket	Flexible Graphite						
12	Stuffing box	A105N+ENP	LF2+ENP	A182 F304	A182 F316	A182 F304L	A182 F316L	A182 F51
13	Bolt	A193 B7/B7M	A320 L7/L7M	A193 B8/B8M				
14	Nut	A194 2H/2HM	A194 4/4M	A194 8/8M				
15	Spring	INCONEL X-750						
16	Screw	A193 B7	A320 L7	A193 B8/B8M				
17	Gasket	PTFE						
18	Flat key	Carbon Steel						
19	Shaft sleeve	PTFE						
20	Stem packing	PTFE Flexible Graphite						
21	Thrust washer	PTFE						
22	Packing gland	ASTM A105N	A350 LF2	A182 F304	A182 F316	A182 F304L	A182 F316L	A182 F51
23	Shaft sleeve	PTFE						
24	Support plate	ASTM A105N	A350 LF2	A182 F304	A182 F316	A182 F304L	A182 F316L	A182 F51
25	Yoke	Carbon Steel						
26	Pin	Carbon Steel						
27	Small check valve	ASTM A105N	A350 LF2	A182 F304	A182 F316	A182 F304L	A182 F316L	A182 F51
28	Grease injector	Carbon steel	Carbon steel	A182 F304	A182 F316	A182 F304L	A182 F316L	A182 F51
29	Vent plug	Carbon steel	Carbon steel	A182 F304	A182 F316	A182 F304L	A182 F316L	A182 F51
30	Drain plug	Carbon steel	Carbon steel	A182 F304	A182 F316	A182 F304L	A182 F316L	A182 F51
31	Lifting lug	Carbon Steel						
32	Support feet	Carbon Steel						

※ Suitable for H₂S service and meet requirement of NACE MR 0175.

API Trunnion Ball Valve

GENERAL VALVE

Construction feature

Close joint and no leakage at middle flange
 Anti-static and blow-out proof stem
 Fire-safe design Split body Locking device
 Self-relieving seat Emergency sealing device
 ISO5211 mounting pad

API598 Pressure Test

Pressure ratings: Class150
 Hydraulic Shell test: 3.2MPa
 Hydraulic Seat test: 2.2MPa
 Air test: 0.6MPa

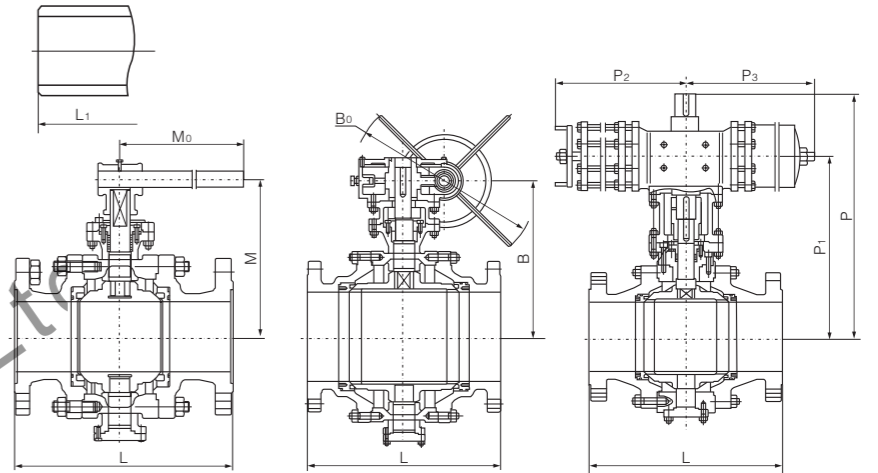

Main size of outside & weight

Pressure	Nominal diameter		Flange		Butt welding		Hand-operated		Worm gear		Air driving and hydraulic driving				Electric driving		Weight (Kg)	
	mm	in	L	L ₁	M	M ₀	B	B ₀	P	P ₁	P ₂	P ₃	H	H ₁	H ₀	RF	BW	
Class 150	50	2	178	216	107	230	-	-	270	174	89	181	-	-	-	12	11	
	65	2 1/2	190.5	241	125	400	-	-	380	248	148	257	-	-	-	16	15	
	80	3	203	283	152	400	-	-	390	258	148	257	-	-	-	22	21	
	100	4	229	305	178	650	-	-	480	322	287	287	-	-	-	35	34	
	125	5	356	381	300	1050	-	-	555	395	287	287	-	-	-	58	55	
	150	6	394	457	330	1050	-	-	665	457	378	378	554	337	200	74	72	
	200	8	457	521	-	-	400	600	805	595	378	378	600	382	200	205	201	
	250	10	533	559	-	-	495	600	840	630	378	378	652	435	200	322	310	
	300	12	610	635	-	-	580	800	975	728	530	530	761	480	280	460	447	
	350	14	686	762	-	-	625	800	1130	883	530	530	771	520	280	576	536	
	400	16	762	838	-	-	670	800	1460	1154	680	680	831	580	280	864	814	
	450	18	864	914	-	-	698	800	1530	1224	680	680	921	670	305	1280	1210	
	500	20	914	991	-	-	840	800	1560	1294	680	680	943	770	305	1600	1500	
	600	24	1067	1143	-	-	1050	800	1145	915	1455	1455	1123	850	305	3540	3000	
	700	28	1245	1346	-	-	1100	800	1160	930	1455	1455	1218	945	400	4500	3710	
	800	32	1372	1524	-	-	1150	800	1460	1100	1665	1665	1328	1055	400	5940	4870	
900	36	1524	1727	-	-	1230	800	1540	1180	1665	1665	1696	1130	460	7540	6010		
1000	40	1753	1956	-	-	1320	800	1630	1280	1960	1960	1925	1240	460	9320	7400		

API Trunnion Ball Valve

GENERAL VALVE

Construction feature

Close joint and no leakage at middle flange;
Anti-static and blow-out proof stem;
Fire-safe design; Split body; Locking device;
Self-relieving seat; Emergency sealing device
ISO5211 mounting pad.

API598 Pressure Test

Pressure ratings: Class300
Hydraulic Shell test: 7.8MPa
Hydraulic Seat test: 5.7MPa
Air test: 0.6MPa

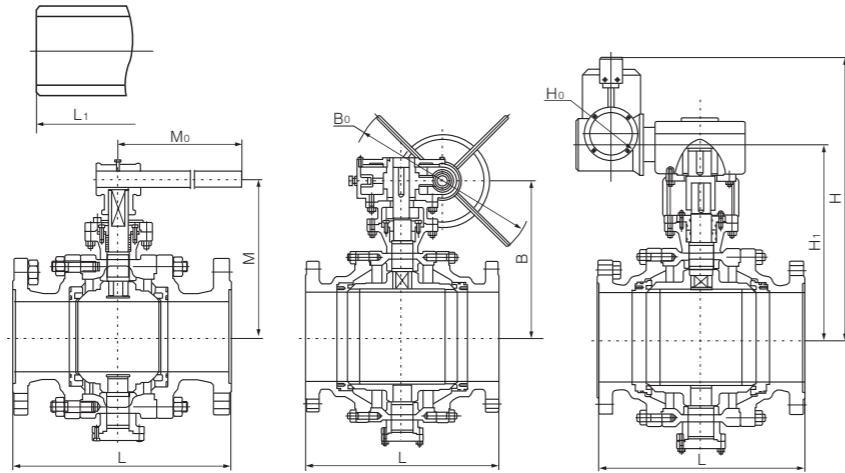

API Trunnion Ball Valve

GENERAL VALVE

Construction feature

Close joint and no leakage at middle flange;
Anti-static and blow-out proof stem;
Fire-safe design; Split body; Locking device;
Self-relieving seat; Emergency sealing device;
ISO5211 mounting pad.

API598 Pressure Test

Pressure ratings: Class600
Hydraulic Shell test: 15.6MPa
Hydraulic Seat test: 11.4MPa
Air test: 0.6MPa

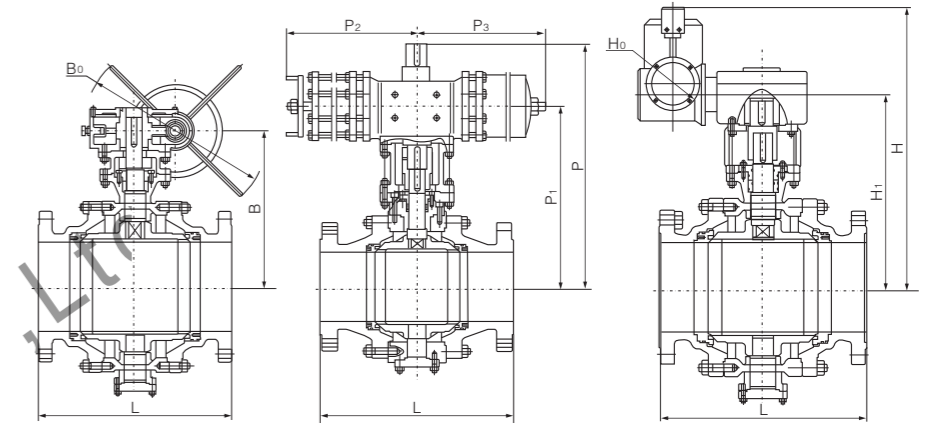

Main size of outside & weight

Pressure	Nominal diameter		Flange	Butt welding		Hand-operated		Worm gear		Air driving and hydraulic driving				Electric driving			Weight (Kg)	
	mm	in	L	L1	M	Mo	B	B0	P	P1	P2	P3	H	H1	H0	RF	BW	
Class 300	50	2	216	216	107	230	-	-	270	210	148	181	-	-	-	15	11	
	65	2 1/2	241	241	125	400	-	-	380	250	148	257	-	-	-	24	18	
	80	3	283	283	152	400	-	-	390	295	287	287	-	-	-	30	22	
	100	4	305	305	178	650	-	-	455	325	287	287	-	-	-	55	45	
	125	5	381	381	300	1050	-	-	580	390	378	378	-	-	-	67	69	
	150	6	403	403	330	1050	-	-	595	390	378	378	554	337	200	118	98	
	200	8	502	521	-	-	400	600	595	530	378	378	600	382	200	255	225	
	250	10	568	559	-	-	495	600	736	700	530	530	652	435	200	370	330	
	300	12	648	635	-	-	580	800	945	750	580	580	761	480	280	533	493	
	350	14	762	762	-	-	625	800	995	885	680	680	771	520	280	640	600	
	400	16	838	838	-	-	670	800	1280	975	680	680	831	580	280	1030	930	
	450	18	914	914	-	-	698	800	1480	1080	680	680	921	670	305	1540	1400	
	500	20	991	991	-	-	840	800	1555	1155	1455	1455	943	770	305	2100	1900	
	600	24	1143	1143	-	-	1050	800	1380	930	1455	1455	1123	850	305	3430	2860	
	700	28	1346	1346	-	-	1100	800	1430	980	1665	1665	1218	945	400	4960	4140	
	800	32	1524	1524	-	-	1150	800	1750	1150	1665	1665	1328	1055	400	6760	5640	
900	36	1727	1727	-	-	1230	800	1540	1180	1960	1960	1696	1130	460	9640	8040		
1000	40	2083	2083	-	-	1320	800	1630	1280	1960	1960	1925	1240	460	11730	9680		

Main size of outside & weight

Pressure	Nominal diameter		Flange	Butt welding		Hand-operated		Worm gear		Air driving and hydraulic driving				Electric driving			Weight (Kg)	
	mm	in	L	L1	M	Mo	B	B0	P	P1	P2	P3	H	H1	H0	RF	BW	
Class 600	50	2	292	292	110	230	-	-	270	210	150	257	-	-	-	35	29	
	65	2 1/2	330	330	155	400	-	-	-	-	-	-	-	-	-	38	31	
	80	3	356	356	200	400	-	-	520	295	287	287	-	-	-	55	45	
	100	4	406	406	-	-	235	600	640	325	287	287	-	-	-	102	78	
	150	6	495	495	-	-	300	800	730	390	378	378	554	337	200	232	182	
	200	8	597	597	-	-	375	800	840	530	378	378	600	382	200	390	310	
	250	10	673	673	-	-	445	800	1015	700	530	530	652	480	200	710	590	
	300	12	762	762	-	-	515	800	1120	750	530	530	761	520	280	960	790	
	350	14	826	826	-	-	550	800	1225	885	680	680	771	594	280	1700	1490	
	400	16	902	902	-	-	615	800	1480	1080	680	680	831	632	280	1970	1720	
	450	18	978	978	-	-	750	800	-	-	-	-	921	670	305	2180	1830	
	500	20	1054	1054	-	-	810	800	1480	1080	680	680	943	770	305	3250	2770	
	600	24	1232	1232	-	-	1050	800	1365	915	1665	1665	1123	850	305	4880	4030	
	700	28	1397	1397	-	-	1100	800	1430	980	1665	1665	1218	945	460	6700	5610	
	800	32	1651	1651	-	-	1180	800	-	-	-	-	1328	1055	460	8470	7060	
	900	36	1880	1880	-	-	1275	800	-	-	-	-	1815	1130	600	12080	10070	
1000	40	2300	2300	-	-	1370	800	-	-	-	-	1925	1240	600	15420	12850		

API Trunnion Ball Valve

GENERAL VALVE

Construction feature

Close joint and no leakage at middle flange;
Anti-static and blow-out proof stem;
Fire-safe design; Split body; Locking device;
Self-relieving seat; Emergency sealing device;
ISO5211 mounting pad.

API598 Pressure Test

Pressure ratings: Class900
Hydraulic Shell test: 23.3MPa
Hydraulic Seat test: 17.1MPa
Air test: 0.6MPa

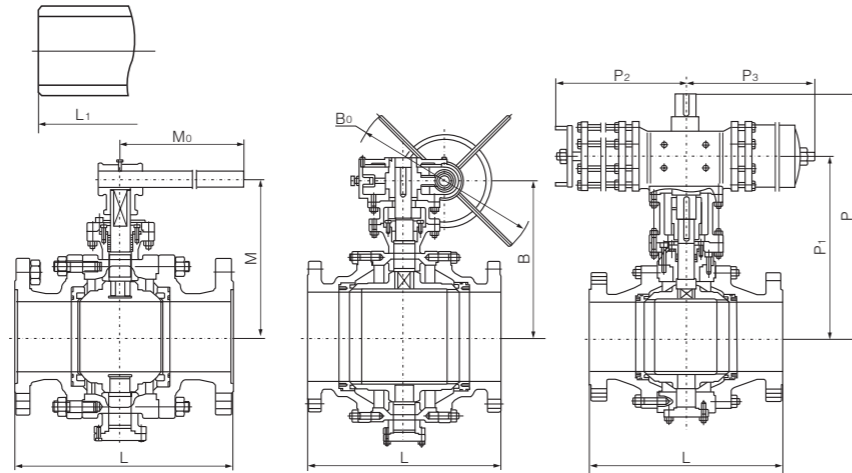

Main size of outside & weight

Pressure	Nominal diameter		Flange	Butt welding	Hand-operated		Worm gear		Air driving and hydraulic driving				Electric driving			Weight (Kg)	
	mm	in	L	L ₁	M	Mo	B	B ₀	P	P ₁	P ₂	P ₃	H	H ₁	H ₀	RF	BW
Class 900	50	2	292	292	110	650	-	-	270	210	150	257	-	-	-	50	40
	65	2 1/2	330	330	155	650	-	-	-	-	-	-	-	-	-	75	60
	80	3	356	356	200	650	-	-	520	295	287	287	-	-	-	92	70
	100	4	432	432	-	-	235	600	640	480	287	287	-	-	-	146	109
	150	6	559	559	-	-	300	800	730	520	378	378	600	382	200	339	264
	200	8	660	660	-	-	375	800	840	595	530	530	652	480	200	640	540
	250	10	787	787	-	-	445	800	1015	770	530	530	761	520	280	960	800
	300	12	838	838	-	-	515	800	1120	810	680	680	771	594	280	1330	1110
	350	14	889	889	-	-	550	800	1225	1005	1445	1445	831	632	280	1640	1370
	400	16	991	991	-	-	615	800	1375	1155	1445	1445	921	670	305	2240	1910
	450	18	1092	1092	-	-	750	800	-	-	-	-	943	770	305	2770	2310
	500	20	1194	1194	-	-	810	800	1490	1210	1665	1665	1123	850	305	3740	3120
	600	24	1397	1397	-	-	1050	800	1615	1335	1665	1665	1218	945	400	5560	4640
	700	28	1549	1549	-	-	1180	800	1760	1410	1960	1960	1328	1055	400	8070	6730
800	32	1778	1778	-	-	1250	800	-	-	-	-	1458	1135	600	11000	9170	
900	36	2083	2083	-	-	1315	800	-	-	-	-	1855	1170	600	15700	13090	
1000	40	2337	2337	-	-	1420	800	-	-	-	-	1960	1285	600	20040	16700	

API Trunnion Ball Valve

GENERAL VALVE

Construction feature

Close joint and no leakage at middle flange;
Anti-static and blow-out proof stem;
Fire-safe design; Split body; Locking device;
Self-relieving seat; Emergency sealing device;
ISO5211 mounting pad.

API598 Pressure Test

Pressure ratings: Class1500
Hydraulic Shell test: 38.8MPa
Hydraulic Seat test: 28.5MPa
Air test: 0.6MPa

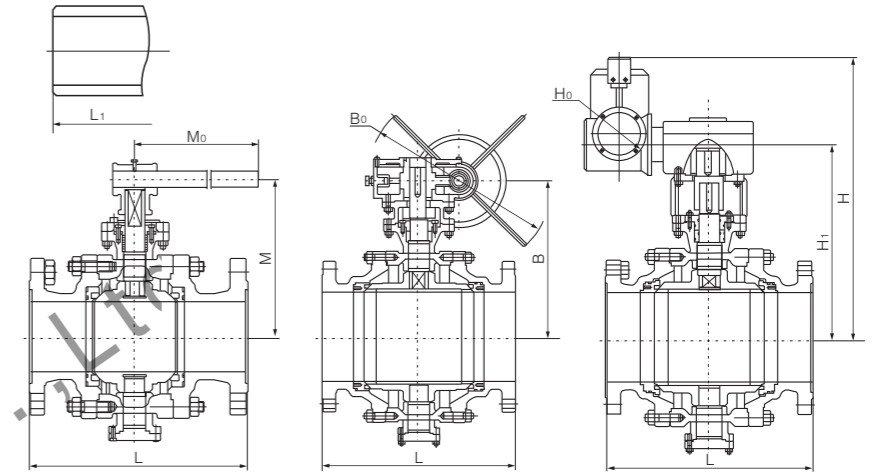

Main size of outside & weight

Pressure	Nominal diameter		Flange	Butt welding	Hand-operated		Worm gear		Air driving and hydraulic driving				Electric driving			Weight (Kg)	
	mm	in	L	L ₁	M	Mo	B	B ₀	P	P ₁	P ₂	P ₃	H	H ₁	H ₀	RF	BW
Class 1500	50	2	368	368	220	650	-	-	520	295	287	287	-	-	-	50	40
	65	2 1/2	419	419	240	650	-	-	-	-	-	-	-	-	-	75	60
	80	3	381	381	260	650	-	-	730	520	378	378	-	-	-	117	82
	100	4	457	457	-	-	300	600	845	595	530	530	600	382	200	216	150
	150	6	610	610	-	-	365	800	1015	770	530	530	761	520	280	532	414
	200	8	737	737	-	-	395	800	1120	815	680	680	771	594	280	870	677
	250	10	838	838	-	-	505	800	1225	1005	1445	1445	831	632	280	1467	1132
	300	12	965	965	-	-	575	800	1375	1155	1445	1445	921	670	305	2270	1777
	350	14	1029	1029	-	-	675	800	1490	1210	1665	1665	943	770	305	3240	2590
	400	16	1130	1130	-	-	765	800	1615	1335	1665	1665	1123	850	305	4645	3780
	450	18	1219	1219	-	-	870	800	1760	1410	1960	1960	1218	945	400	6035	4810
	500	20	1321	1321	-	-	895	800	1760	1410	1960	1960	1328	1055	400	8077	6555
	600	24	1549	1549	-	-	960	800	1760	1410	1960	1960	1458	1135	600	12357	9900
	700	28	1780	1700	-	-	1210	800	-	-	-	-	1904	1180	600	-	-
800	32	2050	1780	-	-	1290	1000	-	-	-	-	1984	1260	600	-	-	

Our butterfly valves are structured to centered seal, single eccentric seal, double eccentric seal, triple eccentric seal and variable eccentric seal. The sealing principles of these structures are stated as following.

Butterfly Valve General Valve



Sealing Principle of Double Eccentric Seal Butterfly Valve

The rotation center of disc (namely the center of valve shaft) and the centerline of body form up a 'b' eccentric on the base of single eccentric butterfly valve. Making the sealing face of disc disengaged from seat sealing face more quickly than single eccentric seal butterfly valves during the process of open and close. Once disc turns to $8^\circ \sim 12^\circ$, the disc sealing face will be completely disengaged from the seat sealing face. Once fully opened, a gap 'Y' will be formed up between the two sealing faces. This type of butterfly valves are designed to have greatly lowered the mechanical wear and extrusion deformation between the two sealing faces, making the sealing performance of butterfly valve much better.

The characteristic of this structure is to make stem axis not only deviated from the center of disc, but also the center of the body. The effect of double eccentric is that, when valve has been opened, disc can be quickly disengaged from seat, thus to greatly eliminate the unnecessary excessive extrusion and scratch between the disc and seat, reduce opening resistance, lower the abrasion and improve the service life of seat. As scratch has been greatly lowered, metal seat can be used for double eccentric butterfly valve, so that butterfly valves are able to be used in high temperature fields. However, as its seal is positioned sealing construction, i.e. the sealing faces disc and seat is lineal contact, disc extruding seat to produce elastic deformation, thus to effect the sealing performance has high requirement on close position, especially for lhasa with metal seat and is given poor pressure endurance. This is why butterfly valves are conventional IV, not resistant to high temperature and leakage.

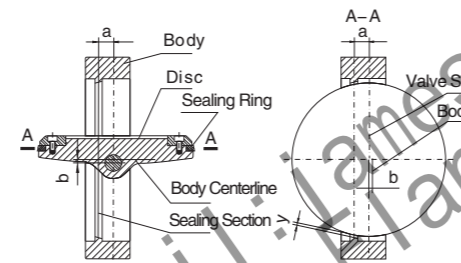

Sealing Structure of Double Eccentric Seal Butterfly Valve

Sealing Principle of Triple Eccentric Seal Butterfly Valve

A B eccentric is formed up between the centerline of seat and the centerline of body on the base of double eccentric butterfly valve, making disc sealing face immediately disengaged from seat sealing face upon the opening of butterfly valve, and in close contact with the seat sealing face upon closing. When fully opened, a gap 'Y', which is the same as that in double eccentric seal butterfly valve, is formed up between the two sealing faces. The design of this type of valves has thoroughly eliminated the mechanical wear and scratch between the two sealing faces, making the sealing performance and service life of butterfly valves greatly improved. When valve is closed, with sealing ring under the extrusion of body sealing face and disc, two upward elastic deformations are produced. the sealing face is fallen under outward tension at long shaft and

inward compressive stress at short shaft. The long and short shafts produce elastic deformation of different directions, thus to maximizing the sealing force between the sealing faces of valve.

This distinctive eccentric combination not only uses cam effect, but also eliminates friction completely, thus to ensure no friction between seat and sealing ring on disc during the 90° stroke of valve, a perfect solution to clear away the possibilities of abrasion and leakage.

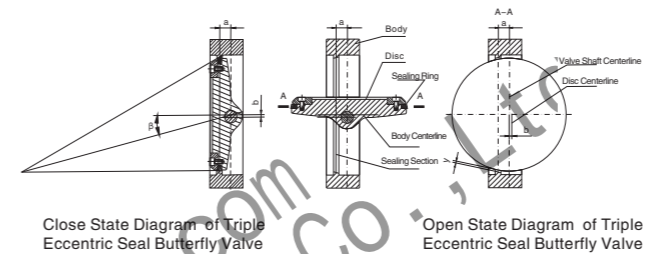

Sealing Principle of Triple Eccentric Seal Butterfly Valve

Butterfly valves are used to open and close (seal type) or adjust the medium flow in pipes in the fields of foodstuff, drinks, chemical, industrial water treatment, high-rise constructions, water supply and drainage etc. They are mainly structured as following:

1. Simple structure, small sizes, light weight and low installation dimensions. According to the types of body connection, they are basically classified to wafer type (including lug wafer type), flanged and welded.

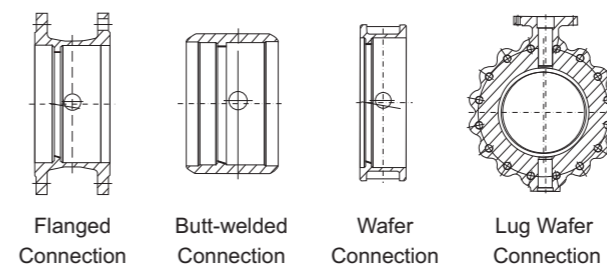

1. Multilayer Hard Seal Structure (See fig. right)

Multilayer hard seal structure is applicable. double and triple eccentric butterfly valves, pressure rating \leq CLASS 600. And triple eccentric butterfly valve can maintain two-way leak-tightness. Multilayer sealing ring is composite of stainless steel and nonmetal material. The nonmetal material can be flexible graphite, PTFE or non asbestos material etc. according to the actual working conditions.

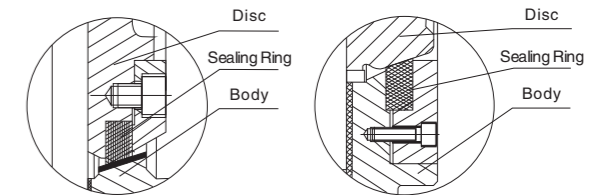

Multilayer Hard Seal Structure

2. Elastic ring hard seal structure (see fig right) is of the structure of J-type metal sealing ring. It is applicable and double eccentric butterfly valves. pressure rating \leq CLASS 300. Provided with fireproof structure to adapt to conditions with great temperature changes, it is featured by outstanding seal, long service life and easy workmanship.

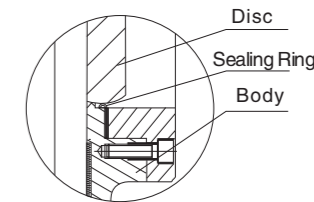

Elastic Ring Hard Seal Structure

3. When butterfly valve is fully opened, flow resistance is low. When partially opened, it may carry out sensitive flow control.
4. Low driving moment, easy and quick operation.

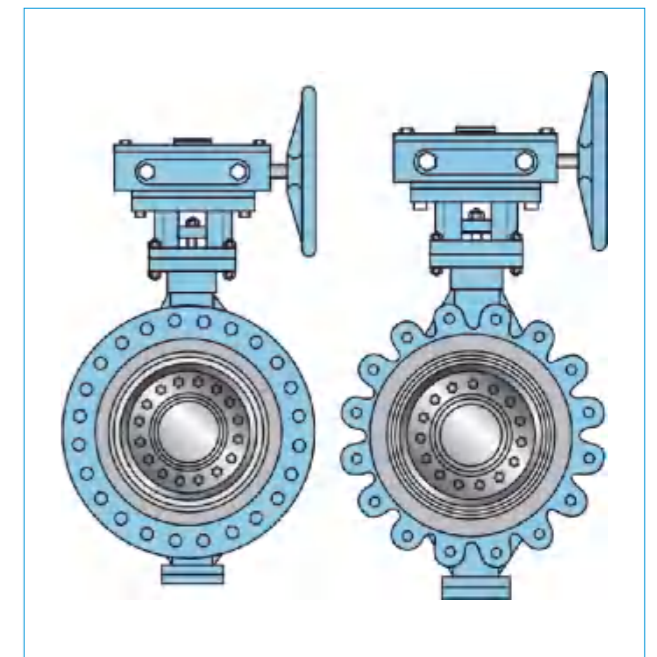

API Butterfly Valve

GENERAL VALVE

The Triple Offset Geometry

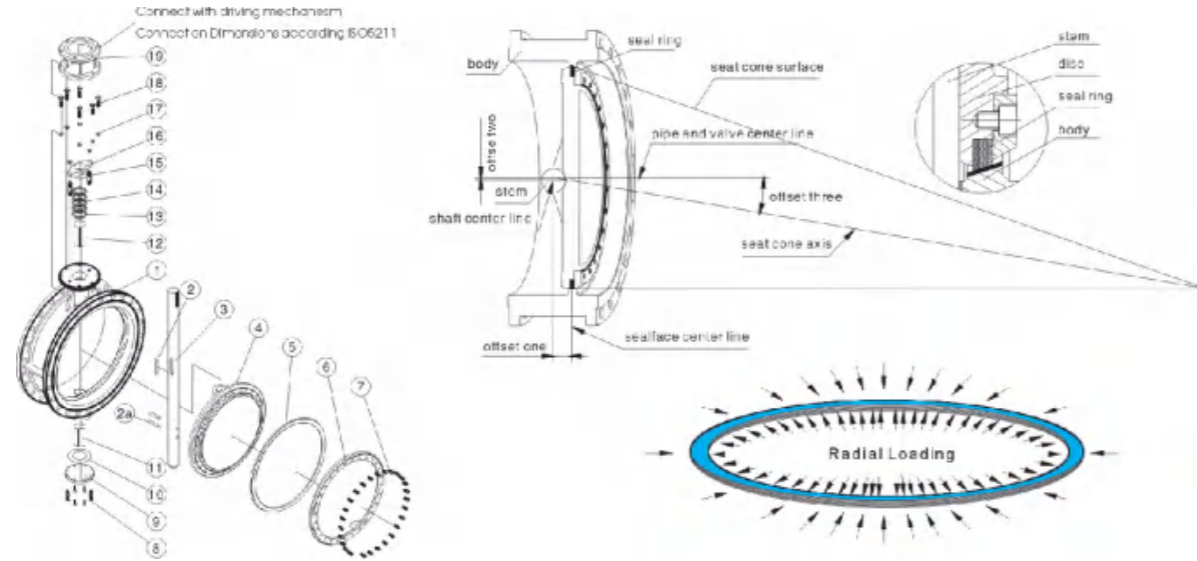

ASTM Materials list of Butterfly Valve

No.	Part Name	Carbon Steel to ASTM	Stainless Steel to ASTM	
1	Body	A216 WCB	A351 CF8	A351 CF8M
2	Key	A182 F6a	SS304	SS316
2a	Pin	A182 F6a	SS304	SS316
3	Stem	A182 F6a	A182 F304	A182F316
4	Disc	A216 WCB	A351 CF8	A351 CF8M
5	Seal Ring	Graphite+304	Graphite+SS304	Graphite+SS316
6	Retainer Flange	A216 WCB	SS304	SS316
7	Bolt	A193 B7	A193 B8	A193 B8M
8	Bolt	A193 B7	A193 B8	A193 B8
9	Cover	A105	A182 F304	A182 F316
10	Gasket	Graphite	PTFE	PTFE
11	Bushing	PTFE+Bronze	PTFE+Bronze	PTFE+Bronze
12	Bushing	PTFE+Bronze	PTFE+Bronze	PTFE+Bronze
13	Packing Seat	SS	SS304	SS316
14	Packing	Graphite	PTFE	PTFE
15	Bolt	-	A193 B8	A193 B8
16	Packing Bushing	SS	-	-
17	Nut	-	-	-
18	Bolt	-	-	-
19	Yoke	Carbon Steel	-	-

API Triple Offset Wafer Butterfly Valve

GENERAL VALVE

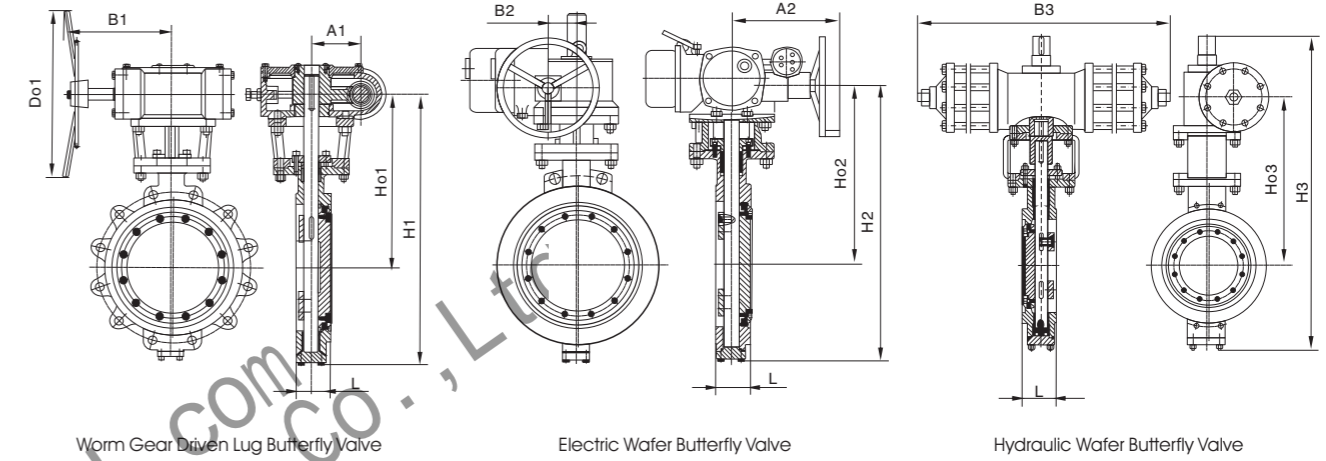

Main size of Wafer Butterfly Valve outside & weight

NPS	L	Worm gear			Electric driving					Air driving and hydraulic driving				weight (kg)	
		H3	Ho3	B3	H1	Ho1	B1	A1	Do1	H2	Ho2	B2	A2	Wafer	Lug
3"	49	-	-	-	320	185	140	63	160	513	263	178	180	9	9
4"	54	-	-	-	342	195	140	63	160	535	282	178	180	11	14
5"	57	-	-	-	365	209	140	63	300	563	293	178	180	15	18
6"	58	-	-	-	415	243	140	63	300	602	322	178	180	17	20
8"	64	690	323	275	510	263	150	84	400	745	296	235	370	25	31
10"	71	750	355	275	567	295	150	84	400	805	325	235	370	40	49
12"	81	955	475	378	665	342	200	108	600	883	365	235	370	61	79
14"	92	1032	513	378	739	385	200	108	600	965	408	235	370	82	107
16"	102	1182	598	530	825	430	240	152	600	1033	443	235	370	123	150
18"	114	1265	635	530	910	469	240	152	800	1120	485	235	370	150	182
20"	127	1335	667	530	990	500	300	168	800	1186	518	235	370	204	253
24"	154	1642	830	680	1210	618	320	192	800	1380	625	235	370	300	398
30"	167	1823	1245	680	1453	875	512	279	400	1583	1005	245	515	454	490
36"	184	2145	1329	860	1775	939	512	279	400	1905	1089	245	515	762	771
40"	217	2235	1488	860	1857	1005	512	279	400	2010	1110	360	540	975	1179
42"	222	2360	1456	860	1980	1086	512	279	400	2120	1216	360	540	1234	1338
46"	254	2445	1505	1080	2070	1110	570	368	600	2175	1260	360	540	1451	1724
48"	254	2535	1564	1080	2165	1194	570	368	600	2235	1324	360	540	1678	1928
54"	305	-	-	-	2382	1477	630	425	800	2412	1503	445	628	2223	2634
60"	333	-	-	-	2684	1617	630	425	800	2699	1687	445	628	2903	3447

API Triple Offset Wafer Butterfly Valve

GENERAL VALVE

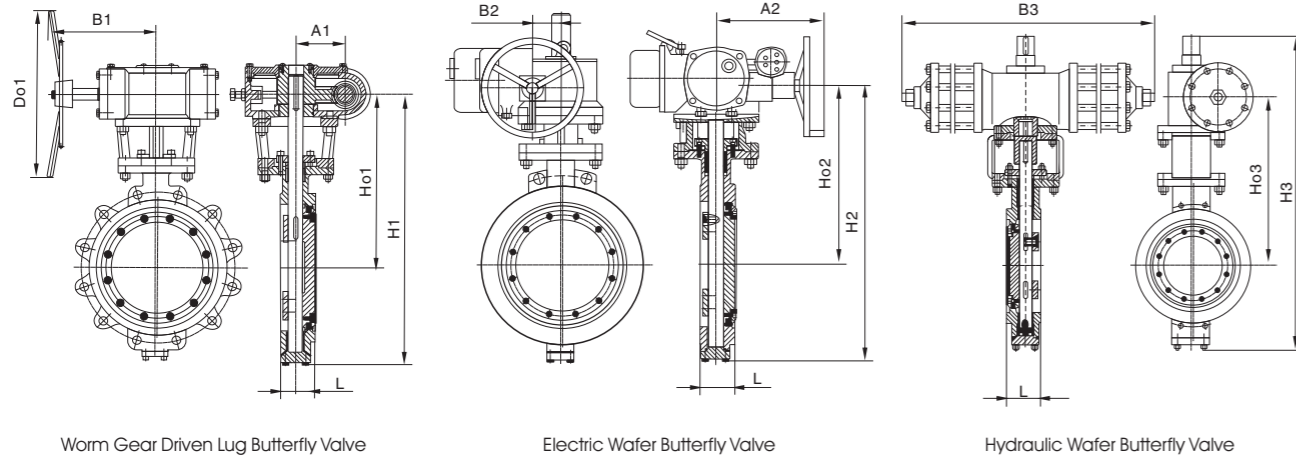

Worm Gear Driven Lug Butterfly Valve

Electric Wafer Butterfly Valve

Hydraulic Wafer Butterfly Valve

CLASS 300 Main size of Wafer Butterfly Valve outside & weight

NPS	L	Worm gear			Electric driving					Air driving and hydraulic driving				weight (kg)	
		H3	Ho3	B3	H1	Ho1	B1	A1	Do1	H2	Ho2	B2	A2	Wafer	Lug
3"	49	-	-	-	320	185	140	63	160	513	263	178	180	13.5	15.5
4"	54	-	-	-	342	195	140	63	160	535	282	178	180	18	21
5"	57	-	-	-	365	209	140	63	300	563	293	178	180	24	28
6"	59	-	-	-	415	243	140	63	300	602	322	178	180	28	34
8"	73	750	368	275	510	263	150	84	400	745	296	235	370	49	60
10"	83	909	442	278	567	295	150	84	400	805	325	235	370	68	88
12"	92	1075	535	530	665	342	200	108	600	883	365	235	370	109	117
14"	117	1158	575	530	739	385	200	108	600	965	408	235	370	186	207
16"	133	1230	610	530	825	430	240	152	600	1033	443	235	370	264	308
18"	149	1462	736	680	910	469	240	152	800	1120	485	235	370	297	408
20"	159	1328	765	680	990	500	300	168	800	1186	518	235	370	363	468
24"	181	-	-	-	1210	618	320	192	800	1380	625	235	370	454	748
30"	254	-	-	-	1937	1180	512	279	600	1516	716	360	540	816	1338
36"	305	-	-	-	2198	1298	570	368	600	1669	794	360	540	1429	2154
42"	324	-	-	-	2318	1358	570	368	600	1914	914	360	540	2155	2427

API Triple Offset Wafer Butterfly Valve

GENERAL VALVE

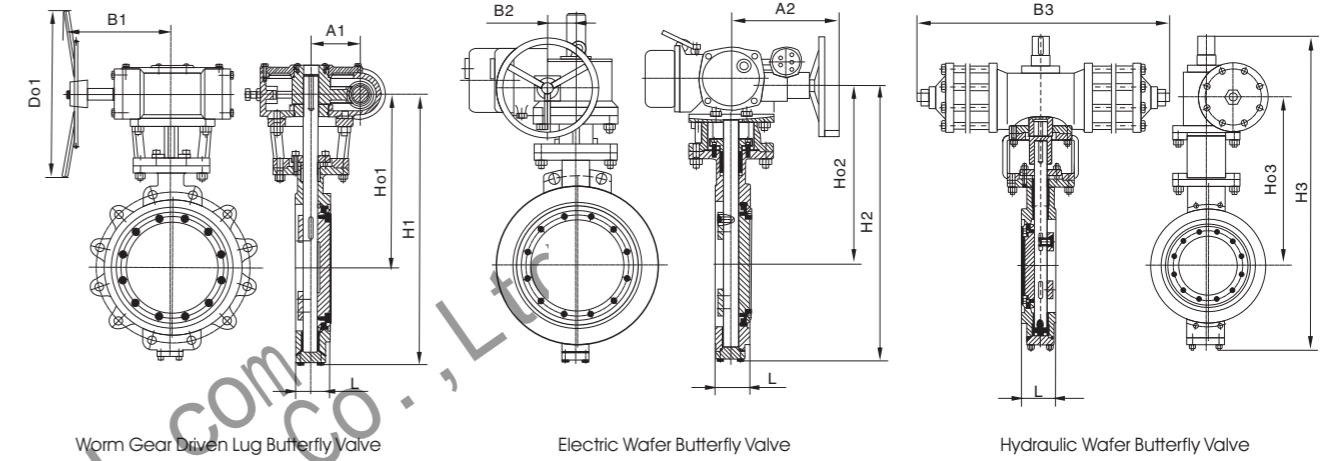

Worm Gear Driven Lug Butterfly Valve

Electric Wafer Butterfly Valve

Hydraulic Wafer Butterfly Valve

CLASS 600 Main size of Wafer Butterfly Valve outside & weight

NPS	L	Worm gear			Electric driving					Air driving and hydraulic driving				weight (kg)	
		H3	Ho3	B3	H1	Ho1	B1	A1	Do1	H2	Ho2	B2	A2	Wafer	Lug
6"	78	-	-	-	415	243	140	63	300	602	322	178	180	45	56
8"	102	750	368	275	510	263	150	84	400	745	296	235	370	70	94
10"	117	909	442	378	567	295	150	84	400	805	325	235	370	103	141
12"	140	1075	535	530	665	342	200	108	600	883	365	235	370	149	201
14"	155	1158	572	530	739	385	200	108	600	965	408	235	370	243	333
16"	178	1230	610	530	825	430	240	152	600	1033	443	235	370	318	401
18"	200	-	-	-	910	469	240	152	800	1120	485	235	370	431	575
20"	216	-	-	-	990	500	300	168	800	1186	518	235	370	472	708
24"	232	-	-	-	1210	618	320	192	800	1380	625	235	370	826	1061

API Triple Offset Flange Butterfly Valve

GENERAL VALVE

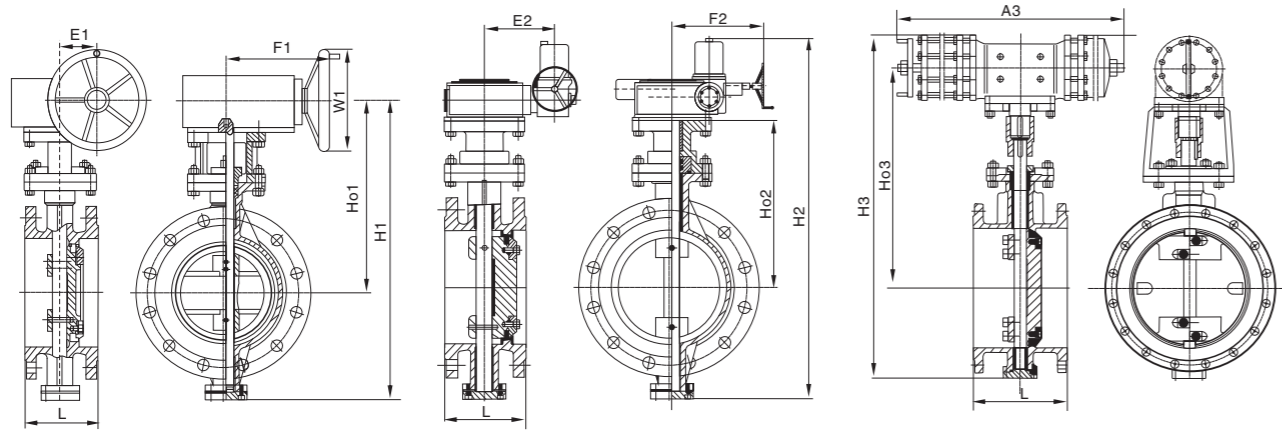

Worm Gear Driven Flanged Butterfly Valve

Electric Flanged Butterfly Valve

Hydraulic Flanged Butterfly Valve

CLASS 150 Main size of Flange Butterfly Valve outside & weight

DN	L	Worm gear					Electric driving				Air driving and hydraulic driving			weight(kg)
		H1	Ho1	E1	F1	W1	H2	Ho2	E2	F2	H3	Ho3	A3	
3"	114	472	350	50	203	203	513	263	180	178	-	-	-	15.4
4"	127	520	386	60	191	203	535	282	180	178	-	-	-	23
5"	140	580	395	60	215	250	563	293	180	178	-	-	-	29
6"	140	653	475	67	289	305	602	322	180	178	-	-	-	33
8"	152	773	565	67	308	460	745	296	370	235	690	323	275	50
10"	165	880	640	86	346	460	805	325	370	235	750	355	275	73
12"	178	989	711	111	403	610	883	365	370	235	955	475	378	108
14"	190	1044	760	60	601	356	965	408	370	235	1032	513	378	143
16"	216	1142	826	60	605	457	1033	443	370	235	1182	598	530	186
18"	222	1228	887	60	652	610	1120	485	370	235	1265	635	530	234
20"	229	1337	959	60	805	762	1186	518	370	235	1335	667	530	277
24"	267	1554	1109	103	763	762	1380	625	370	235	1642	830	680	408
28"	292	1456	956	245	400	315	1587	745	515	245	1711	859	680	653
30"	308	1541	991	310	460	400	1650	777	515	245	1782	910	680	816
32"	318	1611	1036	310	460	400	1717	810	515	245	1856	942	680	914
36"	330	1743	1103	410	480	400	1870	875	540	360	1920	975	680	1157
40"	410	1868	1173	410	480	400	2030	965	540	360	-	-	-	1610
44"	450	1968	1223	410	480	400	2078	1022	540	360	-	-	-	2160
48"	470	2145	1320	520	640	400	2188	1100	540	660	-	-	-	2359
52"	490	2300	1405	520	640	400	2214	1150	565	385	-	-	-	2720
56"	530	2440	1475	520	640	400	2328	1325	565	385	-	-	-	3353
60"	570	2594	1559	450	785	630	2530	1515	565	385	-	-	-	3629

Structural length of valve in the table: DN < 2000, to ISO5752 13series; DN ≥ 2000, to ISO5752 14 series.

You are center of our world

API Triple Offset Flange Butterfly Valve

GENERAL VALVE

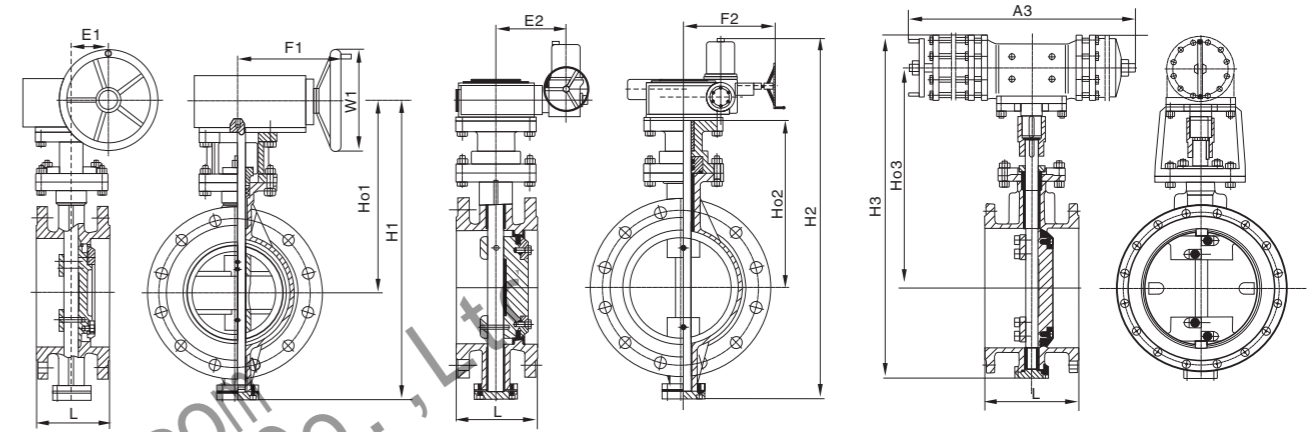

Worm Gear Driven Flanged Butterfly Valve

Electric Flanged Butterfly Valve

Hydraulic Flanged Butterfly Valve

CLASS 300 Main size of Flange Butterfly Valve outside & weight

NPS	L	Worm gear					Electric driving				Air driving and hydraulic driving			weight(kg)
		H1	Ho1	E1	F1	W1	H2	Ho2	E2	F2	H3	Ho3	A3	
2"	108	365	237	35	169	152	407	237	180	178	-	-	-	19
3"	114	378	253	73	229	152	530	253	180	178	-	-	-	29
4"	127	421	274	73	229	305	552	274	180	178	-	-	-	39
5"	140	482	312	73	229	305	580	310	180	178	-	-	-	48
6"	140	543	351	108	254	305	610	351	180	178	-	-	-	54
8"	152	628	392	108	254	305	755	392	370	235	750	368	275	84
10"	165	855	480	133	305	610	816	480	370	235	909	442	378	118
12"	178	812	515	133	305	610	912	515	370	235	1075	535	530	170
14"	191	885	555	194	356	610	980	555	370	235	1158	572	530	231
16"	216	951	590	194	356	356	1057	590	370	235	1230	610	530	299
18"	225	1106	636	194	356	356	1140	636	370	235	1462	736	680	390
20"	229	1308	685	194	356	356	1243	685	515	245	1328	765	680	499
24"	267	1445	934	165	686	686	1420	934	817	351	-	-	-	726
28"	292	1495	1039	165	686	686	1812	1039	817	351	-	-	-	1360
30"	292	1535	1060	165	686	686	1906	1060	817	351	-	-	-	1429
32"	318	1575	1120	165	686	686	2021	1120	817	351	-	-	-	1757
36"	330	1605	1190	165	686	686	2327	1190	973	440	-	-	-	2223
40"	410	1755	1234	165	686	686	2451	1234	973	440	-	-	-	2531
42"	430	2100	1385	429	805	903	2515	1385	973	440	-	-	-	2781
44"	450	2175	1436	429	805	903	2565	1436	973	440	-	-	-	2979
48"	470	2303	1570	399	965	903	2697	1570	973	440	-	-	-	3602

Structural length of valve in the table: DN < 2000, to ISO5752 13series; DN ≥ 2000, to ISO5752 14 series.

You are center of our world

API Triple Offset Flange Butterfly Valve

GENERAL VALVE

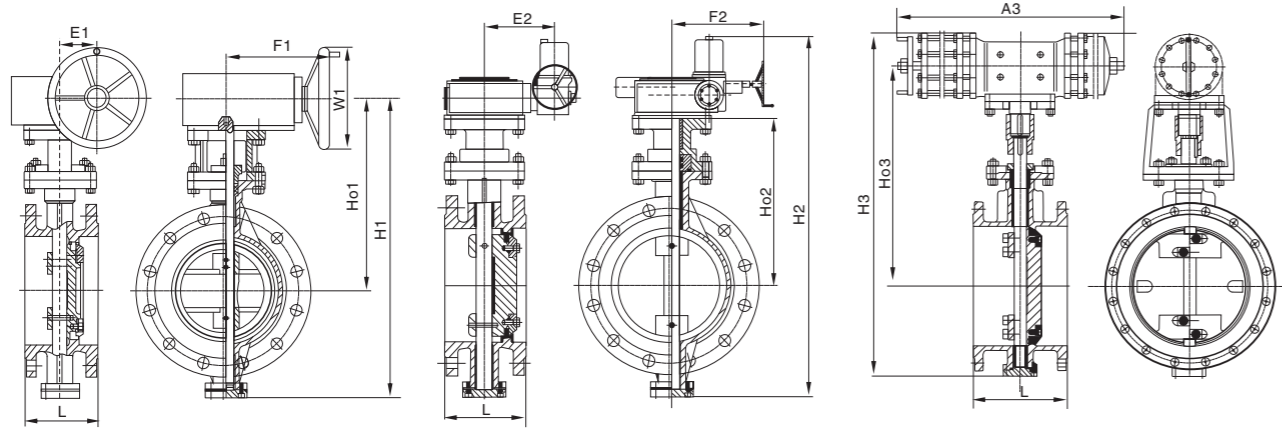

Worm Gear Driven Flanged Butterfly Valve

Electric Flanged Butterfly Valve

Hydraulic Flanged Butterfly Valve

CLASS 600 Main size of Flange Butterfly Valve outside & weight

NPS	L	Worm gear					Electric driving					Air driving and hydraulic driving			weight(kg)
		H1	Ho1	E1	F1	W1	H2	Ho2	E2	F2	H3	Ho3	A3	Worm gear	
3"	180	541	414	63	140	250	606	295	180	178	-	-	-	82	
4"	190	607	447	63	140	250	650	358	180	178	-	-	-	125	
5"	200	680	395	108	200	250	695	371	180	178	-	-	-	165	
6"	210	686	490	152	240	315	743	387	180	178	-	-	-	190	
8"	230	757	536	168	300	315	1055	417	370	235	-	-	-	247	
10"	250	867	641	192	320	315	1172	465	370	235	-	-	-	413	
12"	270	1034	727	237	368	400	1392	546	515	245	-	-	-	576	
14"	290	1087	757	237	368	400	1475	579	515	245	-	-	-	664	
16"	310	1216	825	237	368	400	1557	643	540	360	-	-	-	971	
18"	330	1240	840	269	559	400	1625	673	540	360	-	-	-	1119	
20"	350	1330	978	350	645	400	1679	701	540	360	-	-	-	1639	
24"	390	1583	1070	350	645	400	1834	775	540	360	-	-	-	2082	

API Forged Steel Gate Valves

GENERAL VALVE

Forged Steel Gate Valves General Valve

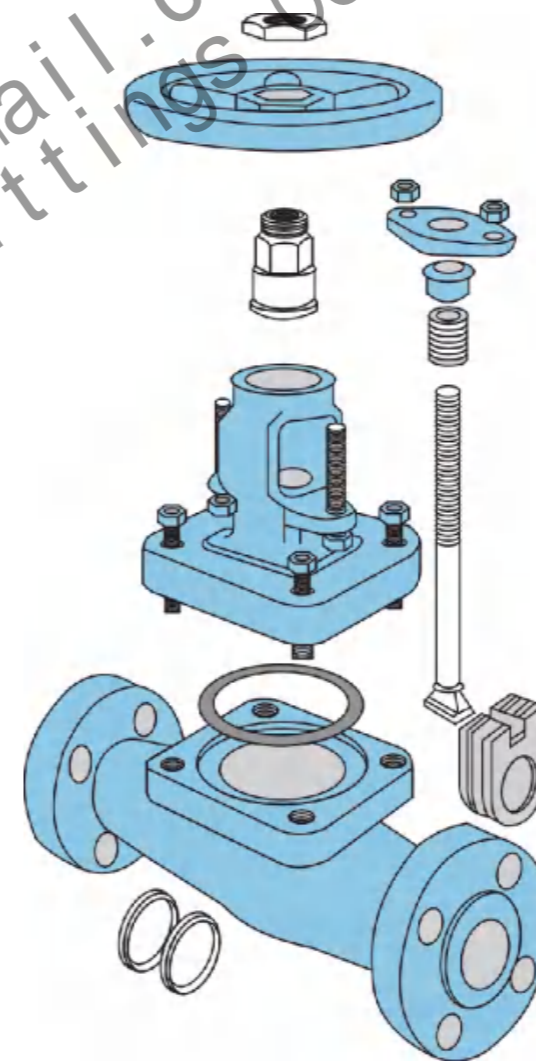

Forged steel gate valves

Our company are available in three bonnet designs. The first design is the Bolted Bonnet, with male-female joint, spiral wound gasket, made in F304L/graphite, Ring joint gasket are also available on request. The second design is the welded bonnet, with a threaded and seal welded joint. On request a full penetration strength welded joint is available. The third design is the pressure seal bonnet, with a threaded and pressure seal bonnet joint.

Construction is as follows

- ※ Full port or conventional port;
- ※ Outside screw and yoke (OS & Y);
- ※ Two piece self-aligning packing gland;
- ※ Bolted bonnet & spiral wound gasket seal bonnet;
- ※ Bolted bonnet with spiral-wound gasket, threaded and seal welded bonnet or threaded and pressure seal bonnet;
- ※ Integral backseat;
- ※ Socket weld ends to ASME B16.11;
- ※ Screwed ends (NPT) to ANSI/ASME B1.20.1.

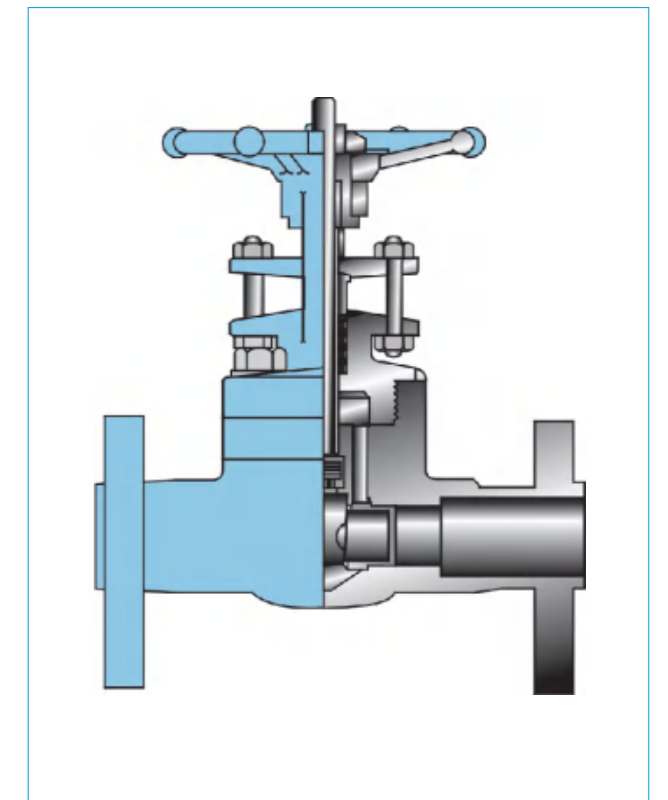

GENERAL VALVE

Application standards

- Design and manufacture conform to API 602, BS5352, ANSI B16.34;
- Connection ends conform to:
 - Socket welded dimension conform to ANSI B16.11
 - Screw ends dimension conform to ANSI B1.20.1
 - Butt-welded conform to ANSI B16.25
 - Flanged ends conform to ANSI B16.5
- Test and inspection conform to: API 598
- Structure features:
 - Bolted bonnet, outside screw and yoke;
 - Welded bonnet, outside screw and yoke.
- Materials conform to ANIS/ASTM.
- Main materials:
 - A105; LF2; F5; F11; F22; 304(L); 316(L); F347; F321; F51; Monel; Alloy Steel.

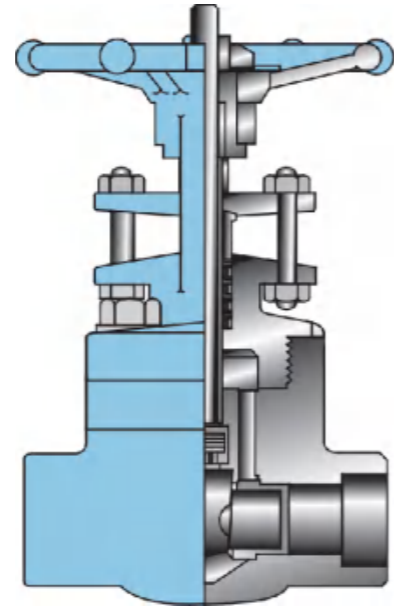

Main part materials list

NO.	Part name	A105/F6a	A105/F6aHFS	LF2/304	F11/F6aHF	F304(L)/304(L)	F316(L)/316(L)	F51/F51
1	Body	A105	A105	LF2	F11	F304(L)	F316(L)	F51
2	Seat	410	410HF	304	410HF	304(L)	316(L)	F51
3	Wedge	F6a	F6a	F304	F6aHF	F304(L)	F316(L)	F51
4	Stem	410	410	304	410	304(L)	316(L)	F51
5	Gasket	304+graphite	304+graphite	304+graphite	304+graphite	304+graphite	316+graphite	316+graphite
6	Bonnet	A105	A105	LF2	F11	F304(L)	F316(L)	F51
7	Bolt	B7	B7	L7	B16	B8(M)	B8(M)	B8M
8	Pin	410	410	410	410	304	304	304
9	Gland	410	410	304	410	304	316	F51
10	Gland eyebolt	B7	B7	L7	B16	B8(M)	B8(M)	B8M
11	Gland flange	A105	A105	LF2	F11	F304	F304	F304
12	Hex nut	2H	2H	2H	2H	8(M)	8(M)	8M
13	Stem nut	410	410	410	410	410	410	410
14	Locking nut	35	35	35	35	35	35	35
15	Nameplate	AL	AL	AL	AL	AL	AL	AL
16	Handwheel	A197	A197	A197	A197	A197	A197	A197
17	Lubricating gasket	410	410	410	410	410	410	410
18	Packing	Graphite	Graphite	Graphite	Graphite	Graphite	Graphite	Graphite

GENERAL VALVE

CL800

Bolted bonnet, full port reduced port outside screw and yoke(OS & Y)
Threaded, butt-welded or socket welded ends; design to API 602

Specification	R.P	1/2	3/4	1	1 1/4	1 1/2	2	2 1/2	3
	F.P	3/8	1/2	3/4	1	1 1/4	1 1/2	2	2 1/2
Face to face	L	79	92	111	120	120	140	178	180
Handwheel diameter	W	100	100	125	160	160	180	200	220
Height	H	161	163	196	223	251	290	333	370
Flow port dimension	d	10.5	13.5	18	24	29	36.5	45	51
Weight(Kg)		2.22	2.39	4.24	5.7	7.05	10.9	16.8	24

CL300-CL1500

Bolted bonnet, full port reduced port outside screw and yoke(OS&Y)
Threaded, butt-welded or socket welded ends; design to API 602

Specification	R.P	1/2	3/4	1	1 1/4	1 1/2	2	2 1/2
	F.P	3/8	1/2	3/4	1	1 1/4	1 1/2	2
Face to face	L	111	111	120	120	140	178	180
Handwheel diameter	W	125	125	160	160	180	200	220
Height	H	191	192	219	243	296	316	370
Flow port dimension	d	10.5	13.5	18	24	29	36.5	45
Weight(Kg)		4.4	4.3	6	7.2	11.4	16	23

CL1500-CL2500

Welded bonnet, full port or red. port, outside screw and yoke(OS&Y)
Threaded, butt-welded or socket welded ends; design to API 602

Specification(NPS)	F.P	Pressure pound level	1/2	3/4	1	1 1/2	2
Face to face	L	CL1500	110	150	150	210	235
Handwheel diameter	W	CL1500	110	130	130	180	250
Height	H	CL1500	277	300	390	400	435
Flow port dimension	d	CL1500	14	17	22	35	37
Weight(Kg)		CL1500	5.1	11	12.1	22	37

CL1500-CL2500

Pressure seal bonnet, full port outside screw and yoke(OS & Y)
Socket welded ends, design conform to ASME B16.34

Specification	F.P	Pressure pound level	1/2	3/4	1	1 1/4	1 1/2	2
Face to face	L	CL2500	186	186	186	232	232	279
Handwheel diameter	W	CL2500	200	200	200	280	280	300
Height	H	CL2500	325	325	327	467	468	540
Flow port dimension	d	CL2500	14	14	19	25	30	36.5
Weight(Kg)		CL2500	12.3	11.6	10.8	26.0	28.4	60.0

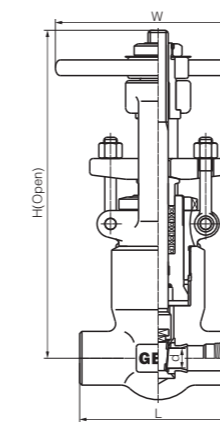
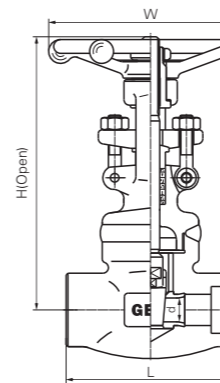
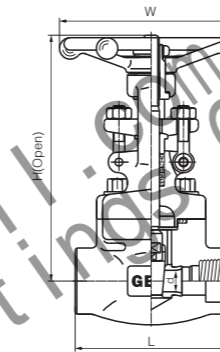
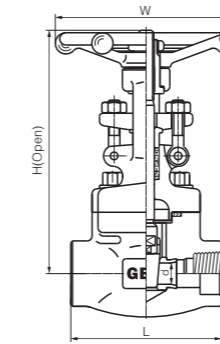

GENERAL VALVE

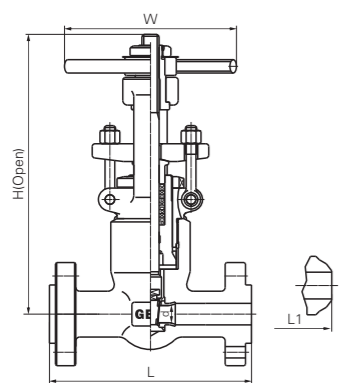
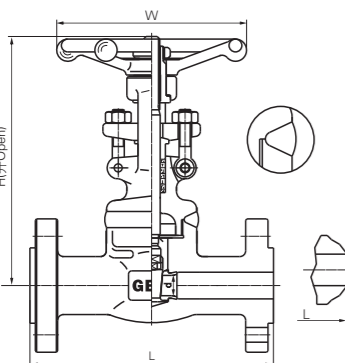
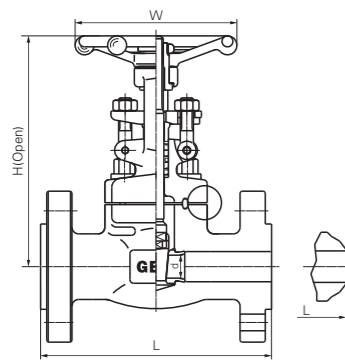
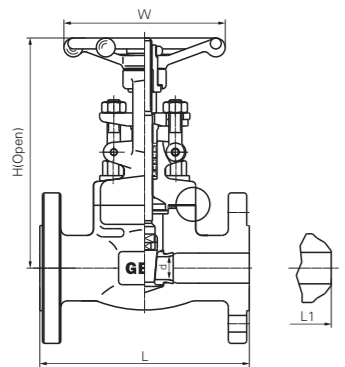

CL150-300-600

Bolted bonnet, red., outside screw and yoke(OS & Y)
Flange-welded or butt-welded ends; design to API602;BS5352

Specification			1/2	3/4	1	1 1/4	1 1/2	2	2 1/2
Face to face (mm)	CL150	L(RF)	108	117	127	140	165	178	190
	CL300	L1(BW)	140	152	165	178	190	216	241
	CL600		165	190	216	229	241	292	330
Handwheel diameter	W		100	100	125	160	160	180	200
Height	CL150	H	176	184	217	226	250	290	357
	CL300,CL600		161	163	196	226	250	290	357
Flow port dimension	d		10	13.5	18	24	29	36.5	45
Weight (Kg)	CL150	RF	3.4	3.98	6.12	7.2	10.4	15.5	24.5
		BW	2.8	3.3	5.4	7.1	8.2	12.5	20
	CL300	RF	3.77	4.89	7.23	9.6	12.65	18	26.2
		BW	3.5	4.4	6.8	8.1	9.2	15.4	22
	CL600	RF	4.2	5.8	8.8	12.1	15.6	19.5	32
		BW	4.5	5.1	8.2	10.5	12.4	20.1	28

CL900-CL1500

Bolted bonnet, red., outside screw and yoke(OS & Y)
Flange-welded or butt-welded ends; design to API602;BS5352

Specification			1/2	3/4	1	1 1/4	1 1/2	2
Face to face (mm)	L(RF) L1(BW)		216	229	254	279	305	368
	L(RTJ)		216	229	254	279	305	371
Handwheel diameter	W		125	125	160	180	200	220
Height	H		191	192	219	257	296	316
Flow port dimension	d		13.5	18	24	29	36.5	45
Weight (Kg)			7.2	11.5	15.6	16.2	22.6	28.2

CL2500

Welded bonnet, red., outside screw and yoke(OS & Y)
Flange-welded or butt-welded ends; design to API602;BS5352

Specification			1/2	3/4	1	1 1/2	2
Face to face (mm)	L(RF) L1(BW)		264	273	308	384	451
	L(RTJ)		264	273	308	387	454
Handwheel diameter	W		125	160	160	200	240
Height	H		207	240	258	355	370
Flow port dimension	d		13.5	13.5	19	30	36.5
Weight (Kg)			19.5	21.5	42	65	95

CL2500

Pressure seal gate valves, red., outside screw and yoke(OS & Y)
Flange-welded or butt-welded ends; design to ASME B16.34

Specification			1/2	3/4	1	1 1/2	2
Face to face (mm)	L(RF) L1(BW)		264	273	308	384	451
	L(RTJ)		264	273	308	387	451
Handwheel diameter	W		200	200	200	280	300
Height	H		325	325	327	478	540
Flow port dimension	d		13.5	13.5	19	30	36.5
Weight (Kg)			4.6	6.8	7.6	15	21.9

GENERAL VALVE

Forged Steel Globe Valves General Valve

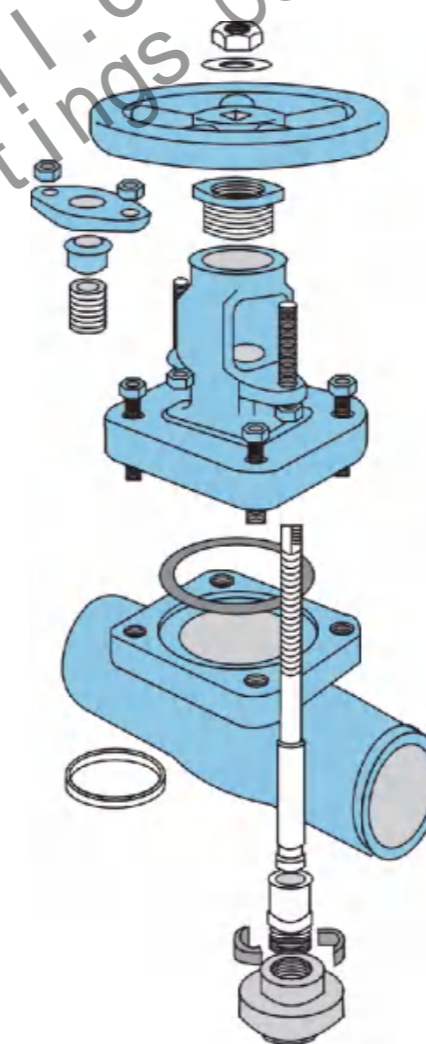

Forged steel globe valves

Our company are available in three bonnet designs. The first design is the Bolted Bonnet, with male-Female joint, spiral wound gasket, made in F304L/graphite, Ring joint gasket are also available on request. The second design is the welded bonnet, with a threaded and seal welded joint. On request a full penetration strength welded joint is available. The third design is the pressure seal bonnet, with a threaded and pressure seal bonnet joint.

Construction is as follows

- * Full port or conventional port;
- * Outside screw and yoke (OS&Y);
- * Two piece self-aligning packing gland;
- * Bolted bonnet with spiral-wound gasket, threaded and seal welded bonnet or threaded and pressure seal bonnet;
- * Integral backseat;
- * Socket weld ends to ASME B16.11;
- * Screwed ends(NPT) to ANSI/ASME B1.20.1;
- * Disc can change for throttle type, needle type, ball type and check type.

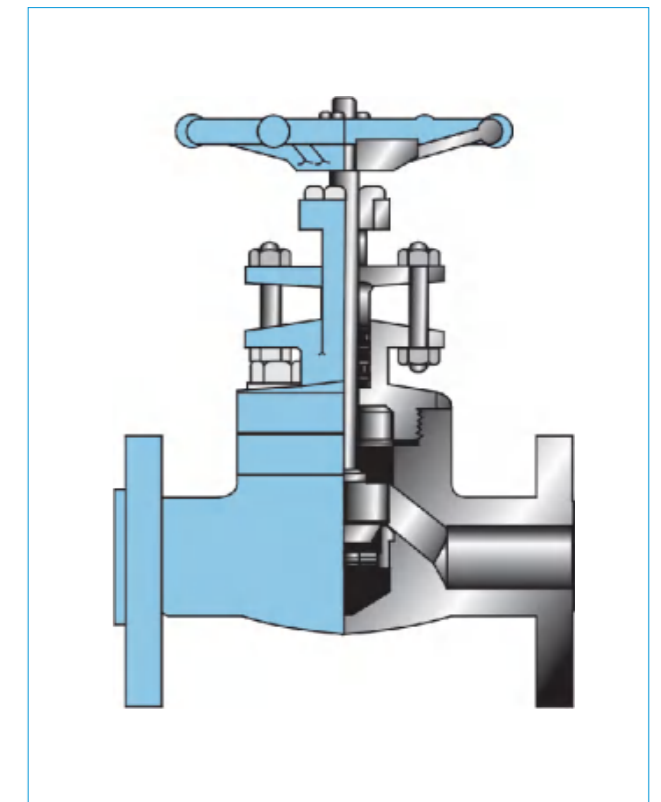

GENERAL VALVE

Application standards

- Design and manufacture conform to BS5352 MSS SP-118;
- Connection ends conform to:
 - Socket welded ends conform to ANSI B16.11
 - Screw ends conform to ANSI B1.20.1
 - Butt-welded ends conform to ANSI B16.25
 - Flanged ends conform to ANSI B16.5
- Test and inspection conform to: API 598
- Structure features: Bolted bonnet, outside screw and yoke; Welded bonnet, outside screw and yoke.
- Materials conform to ANSI/ASTM.
- Main materials: A105; LF2; F5; F11; F22; 304(L); 316(L); F347; F321; F51; Monel; Alloy Steel.

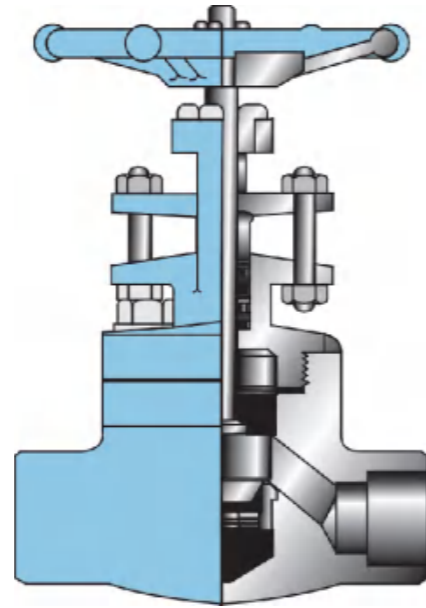

Main part materials list

NO.	Part name	A105/F6a	A105/F6aHFS	LF2/304	F11/F6aHF	F304(L)/304(L)	F316(L)/316(L)	F51/F51
1	Body	A105	A105+HF	LF2	F11+HF	F304(L)	F316(L)	F51
3	Disc	F6a	F6a	F304	F6aHF	F304(L)	F316(L)	F51
4	Stem	410	410	304	410	304(L)	316(L)	F51
5	Gasket	304+ graphite	304+ graphite	304+ graphite	304+ graphite	304+ graphite	316+ graphite	316+ graphite
6	Bonnet	A105	A105	LF2	F11	F304(L)	F316(L)	F51
7	Bolt	B7	B7	L7	B16	B8(M)	B8(M)	B8M
8	Pin	410	410	410	410	304	304	304
9	Gland	410	410	304	410	304	316	F51
10	Gland eyebolt	B7	B7	L7	B16	B8(M)	B8(M)	B8M
11	Gland flange	A105	A105	LF2	F11	F304	F304	F304
12	Hex nut	2H	2H	2H	2H	8(M)	8(M)	8M
13	Stem nut	410	410	410	410	410	410	410
14	Locking nut	35	35	35	35	35	35	35
15	Nameplate	AL	AL	AL	AL	AL	AL	AL
16	Handwheel	A197	A197	A197	A197	A197	A197	A197
18	Packing	Graphite	Graphite	Graphite	Graphite	Graphite	Graphite	Graphite

GENERAL VALVE

CL800

Bolted bonnet, full port or red. port outside screw and yoke(OS & Y) THD., SW or BW ends, design standard: BS5352

Specification	R.P	1/2	3/4	1	1 1/4	1 1/2	2	2 1/2
	F.P	3/8	1/2	3/4	1	1 1/4	1 1/2	2
Face to face	L	79	92	111	120	152	172	200
Handwheel diameter	W	100	100	125	160	160	180	200
Height	H	164	164	203	224	260	300	355
Flow port dimension	d	9	13	17.5	23	30	35	46
Weight(Kg)		2.28	2.37	4.3	5.75	7.8	12.5	17.5

CL900-CL1500

Bolted bonnet, red. port or full port outside screw and yoke(OS&Y) THD., BW or SW ends, design standard: BS5352

Specification	R.P	1/2	3/4	1	1 1/4	1 1/2	2	2 1/2
	F.P	3/8	1/2	3/4	1	1 1/4	1 1/2	2
Face to face	L	111	111	120	152	172	200	220
Handwheel diameter	W	125	125	160	160	180	200	240
Height	H	207	207	240	258	330	355	370
Flow port dimension	d	12	15	20	28	32	40	45
Weight(Kg)		3.7	3.6	6.8	7.6	11.6	15	21.9

CL2500

Welded bonnet (RJ), red. port, outside screw and yoke(OS & Y) SW ends, design standard: ASME B16.34

Specification	F.P	1/2	3/4	1	1 1/2	2
Face to face	L	150	150	210	235	235
Handwheel diameter	W	130	130	250	300	300
Height	H	293	300	390	435	435
Flow port dimension	d	11	14	19	28	35
Weight(Kg)		10	10.3	22.4	38	38

CL2500

Pressure seal bonnet, red. port, outside screw and yoke(OS & Y) SW ends, design standard: ASME B16.34

Specification	F.P	1/2	3/4	1	1 1/4	1 1/2	2
Face to face	L	186	186	186	232	232	279
Handwheel diameter	W	200	200	200	280	280	300
Height	H	375	378	380	490	490	540
Flow port dimension	d	11	14	19	25	28	35
Weight(Kg)		12.3	11.6	10.8	26.0	28.4	60

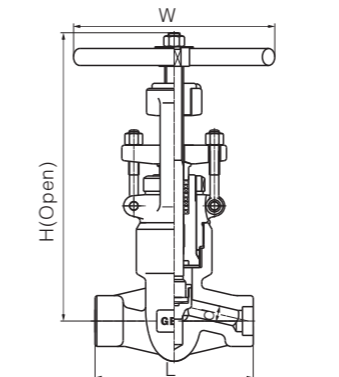
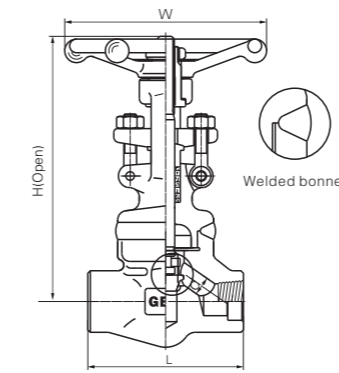
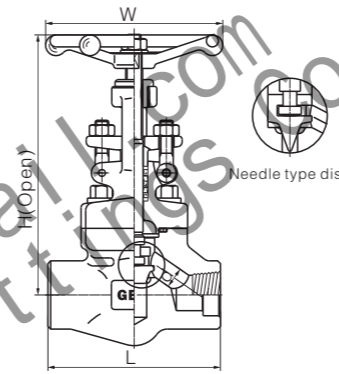
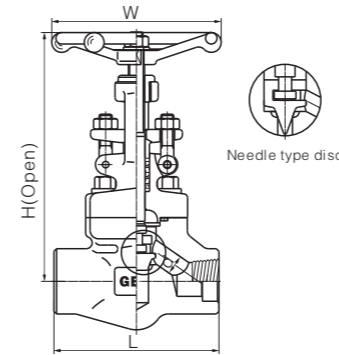

API Forged steel Flange Globe Valve

GENERAL VALVE

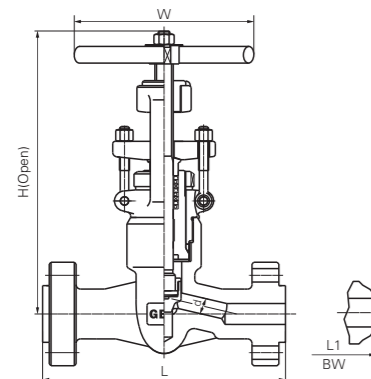
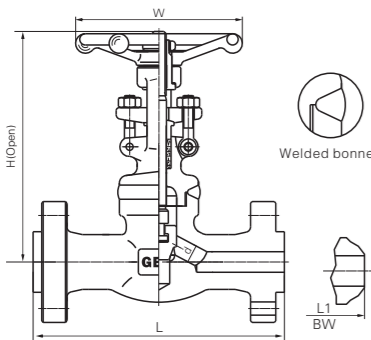
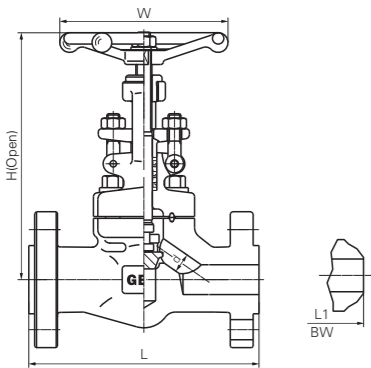
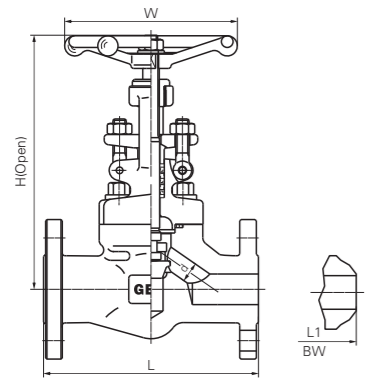

CL150-300-600

Bolted bonnet, reducing port, outside screw and yoke(OS & Y)
Flanged or BW ends, design standard: BS5352

Specification		R.P	1/2	3/4	1	1 1/4	1 1/2	2
Face to face	CL150	L(RF)	108	117	127	140	165	203
	CL300	L1(BW)	152	178	203	216	229	267
	CL600		165	190	216	229	241	292
Handwheel diameter	W		100	100	125	160	160	180
Height	CL150/CL300	H	180	184	217	224	260	300
	CL600		164	164	203	224	260	300
Flow port dimension(mm)	d		9	13	17.5	23	30	35
Weight (Kg)	CL150	R F	3.45	4.00	6.19	9.6	10.5	17
		BW	2.3	3.6	7.8	8.2	12.0	15.0
	CL300	R F	3.8	5.1	7.2	12	13.5	19.7
		BW	2.8	4.0	8.5	9.2	12.6	16.8
	CL600	R F	5.6	7.8	12.5	17	23.5	38.8
		BW	3.4	4.7	9.2	10.5	13.3	18.9

CL900-CL1500

Bolted bonnet, reducing port, outside screw and yoke(OS & Y)
Flanged or BW ends, design standard: BS5352

Specification		F.P	1/2	3/4	1	1 1/4	1 1/2	2
Face to face (mm)	L(RF),L1(BW)		216	229	254	279	305	368
	L(RTJ)		216	229	254	279	305	371
Handwheel diameter(mm)	W		125	125	160	160	180	200
Height(mm)	H		207	207	230	160	300	355
Flow port dimension(mm)	d		12	15	20	28	32	40
Weight (Kg)			11	13.2	17.4	19	24.5	31

CL2500

Welded bonnet, reducing port, outside screw and yoke(OS & Y)
Flanged or BW ends, design standard: ASME B16.34

Specification		F.P	1/2	3/4	1	1 1/4	1 1/2	2
Face to face (mm)	L(RF),L1(BW)		264	273	308	384	451	
	L(RTJ)		264	273	308	387	454	
Handwheel diameter(mm)	W		125	160	200	250	240	
Height(mm)	H		207	240	258	355	300	
Flow port dimension(mm)	d		11	14	19	28	35	
Weight (Kg)			19.5	21.5	42	65	95	

CL2500

Pressure seal bonnet, reducing port, outside screw and yoke(OS & Y)
Flanged or BW ends, design standard: ASME B16.34

Specification		F.P	1/2	3/4	1	1 1/4	1 1/2	2
Face to face (mm)	L(RF),L1(BW)		264	273	308	349	384	451
	L(RTJ)		264	273	308	349	387	454
Handwheel diameter(mm)	W		200	200	280	280	280	300
Height(mm)	H		320	320	320	440	440	490
Flow port dimension(mm)	d		11	14	19	25	28	35
Weight (Kg)			21.5	24.7	30.4	48.1	58.1	130

API Forged Steel Check Valves

GENERAL VALVE

Forged Steel Check Valves

General Valve

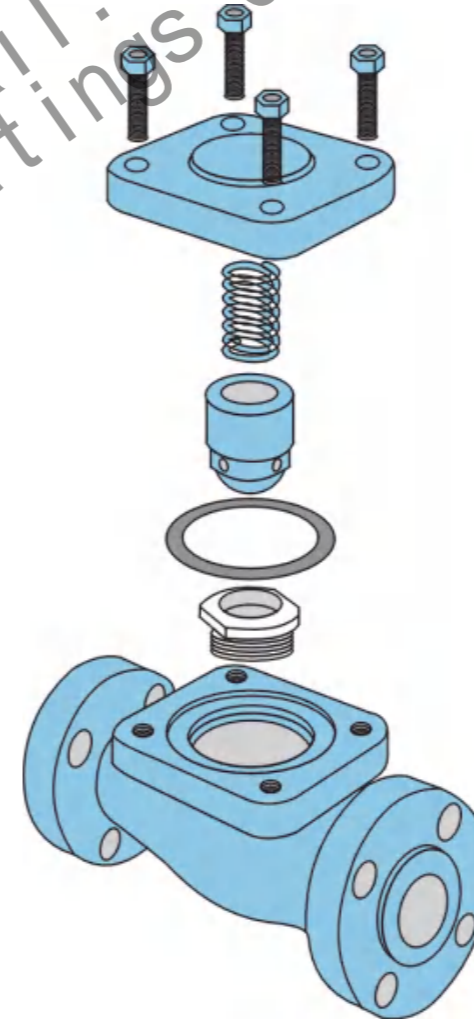

Forged steel check valves

Our company are available in three bonnet designs. The first design is the Bolted Bonnet, with male-female joint, spiral wound gasket, made in F304L/graphite, Ring joint gasket are also available on request. The second design is the welded bonnet, with a threaded and seal welded joint. On request a full penetration strength welded joint is available. The third design is the pressure seal bonnet, with a threaded and pressure seal bonnet joint. The check valves are also available in three different design configurations. These are piston check, ball check, or swing check designs.

Construction is as follows

- ※ Full port or conventional port;
- ※ Lift type check valves;
- ※ Ball type check valves;
- ※ Swing type check valves;
- ※ According to requirement equip inside spring;
- ※ Bolted bonnet with spiral-wound gasket, threaded and seal welded bonnet or threaded and pressure seal bonnet;
- ※ Socket weld ends to ASME B16.11;
- ※ Screwed ends (NPT) to ANSI/ASME B1.20.1;
- ※ Disc can change for soft seal disc and ball disc.

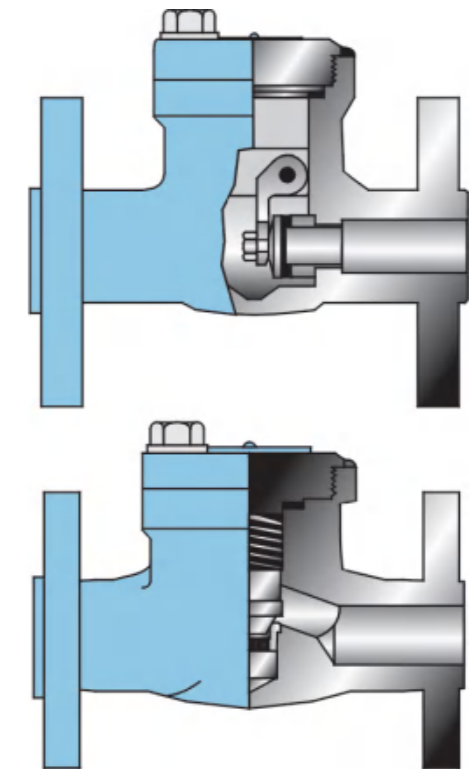

GENERAL VALVE

Application standards

- Design and manufacture conform to BS5352 MSS SP-118;
- Connection ends conform to:
 - Socket welded ends conform to ANSI B16.11
 - Screw ends conform to ANSI B1.20.1
 - Butt-welded ends conform to ANSI B16.25
 - Flanged ends conform to ANSI B16.5
- Test and inspection conform to: API 598
- Structure features: Bolted bonnet
- Materials conform to ANSI/ASTM.
- Main materials: A105; LF2; F5; F11; F22; 304(L); 316(L); F347; F321; F51; Monel; Alloy Steel.

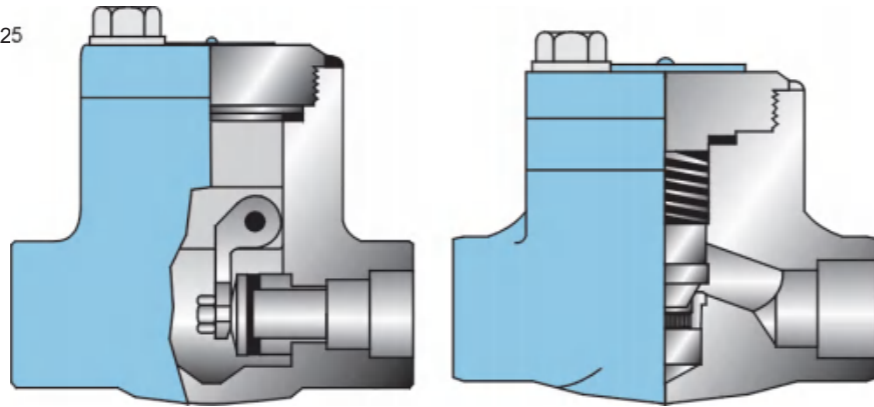

Main part materials list

NO.	Part name	A105/F6a	A105/F6aHFS	LF2/304	F11/F6aHF	F304(L)/304(L)	F316(L)/316(L)	F51/F51
1	Body	A105	A105	LF2	F11	F304(L)	F316(L)	F51
2	Seat ring	410	410HF	304	410HF	304(L)	316(L)	F51
3	Disc	F6a	F6a	F304	F6aHF	F304(L)	F316(L)	F51
5	Gasket	304+Graphite	304+Graphite	304+Graphite	304+Graphite	304+Graphite	316+Graphite	316+Graphite
6	Bonnet	A105	A105	LF2	F11	F304(L)	F316(L)	F51
7	Bolt	B7	B7	L7	B16	B8(M)	B8(M)	B8M
15	Nameplate	AL	AL	AL	AL	AL	AL	AL
32	Revit	AL	AL	AL	AL	AL	AL	AL
33	Steel ball	430	430	304	STL	316(L)	316(L)	STL
34	Disc nut	2H	2H	8	8	8(M)	8(M)	8M
35	Hinge	410	410	304	410	316(L)	316(L)	F51
36	Pin	410	410	304	410	304(L)	316(L)	F51

GENERAL VALVE

CL800

BB, Full Bore or Red. Bore, THD or BW or SW ends, Design Standard: BS5352

Specification	R.P		1/2	3/4	1	1 1/4	1 1/2	2	2 1/2
	F.P	-	3/8	1/2	3/4	1	1 1/4	1 1/2	2
Face to face	L	Lift	79	92	111	120	152	172	200
		Swing	79	92	111	120	120	140	178
Height	H	Lift	61	61	78	84	84	118	132
		Swing	61	61	78	84	84	120	133
Flow port dimension	d	Lift	9	13	17.5	23	30	35	46
		Swing	10.5	13.5	18	24	29	36.5	45
Weight(Kg)		Lift	1.5	1.7	3.3	4.2	4.2	10.5	12.5
		Swing	1.5	1.7	3.3	4.2	4.2	8.5	10.9

CL900-CL1500

BB, Full Bore or Red. Bore, THD or BW or SW ends, Design Standard: BS5352

Specification	R.P		1/2	3/4	1	1 1/4	1 1/2	2	2 1/2
	F.P	-	3/8	1/2	3/4	1	1 1/4	1 1/2	2
Face to face	L	Lift	92	111	111	120	152	172	200
		Swing	92	111	111	120	120	140	178
Height	H	Lift	61	78	78	84	103	118	132
		Swing	61	78	78	84	101	120	133
Flow port dimension	d	Lift	7	12	15	20	28	32	40
		Swing	8	10.5	13.5	18	24	29	45
Weight(Kg)		Lift	1.5	3.4	3.3	4.2	6.3	10.5	12.5
		Swing	1.5	3.4	3.3	4.2	5.0	8.5	10.9

CL150-300-600

BB, Red. Bore, Flanged or BW ends, Design Standard: BS5352

Specification	R.P		1/2	3/4	1	1 1/4	1 1/2	2		
	L(RF)	L1(BW)								
Face to face	CL150		108	118	127	140	165	203		
	CL300		153	178	203	216	229	267		
	CL600		165	191	216	229	241	292		
Height	CL150	H	77	81	93	95	103	118		
	CL300/600		61	78	84	101	120	133		
Flow port dimension(mm)	d									
			CL150	RF	3.6	4.6	8.5	9.2	12.5	14.8
			BW	3.0	3.6	7.6	8.5	11.3	13.6	
			CL300	RF	3.7	4.8	8.8	9.6	13.7	17.8
			BW	3.2	4.3	8.0	8.6	12.7	16.2	
			CL600	RF	4.0	5.8	9.5	10.4	15.6	24.5
BW	3.4	5.1	8.8	9.2	14.8	22.5				

CL150-300-600

BB, Red. Bore, Flanged or BW ends, Design Standard: BS5352

Specification	R.P		1/2	3/4	1	1 1/4	1 1/2	2		
	L(RF)	L1(BW)								
Face to face	CL150		108	118	127	140	165	203		
	CL300		153	178	203	216	229	267		
	CL600		165	191	216	229	241	292		
Height	CL150	H	77	81	93	95	103	118		
	CL300/600		61	78	84	101	120	133		
Flow port dimension(mm)	d									
			CL150	RF	3.6	4.6	8.5	9.2	12.5	14.8
			BW	3.0	3.6	7.6	8.5	11.3	13.6	
			CL300	RF	3.7	4.8	8.8	9.6	13.7	17.8
			BW	3.2	4.3	8.0	8.6	12.7	16.2	
			CL600	RF	4.0	5.8	9.5	10.4	15.6	24.5
BW	3.4	5.1	8.8	9.2	14.8	22.5				

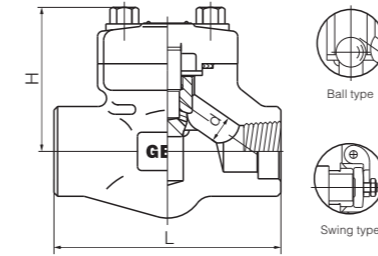

Spring-load acc. to client's requirement

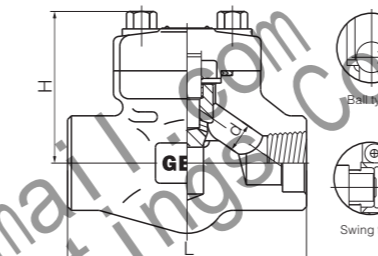

Spring-load acc. to client's requirement

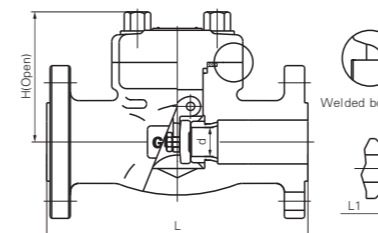
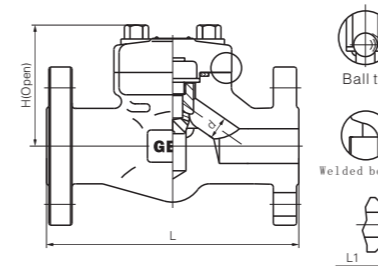

Super: Jameschen324@gmail.com
Flange & Pipe Fittings Co., Ltd.

Flange size

GENERAL VALVE

Flange size

General Valve



Jameschen324@gmail.com
Super Flange & Pipe Fittings Co., Ltd.

Flange size

GENERAL VALVE

ASME B16.5, B16.47A (MSS SP-44)

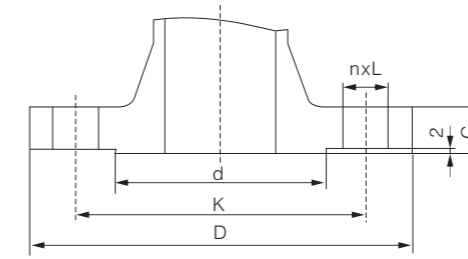

CLASS 300LB RF PN 5.0MPa Tu surface

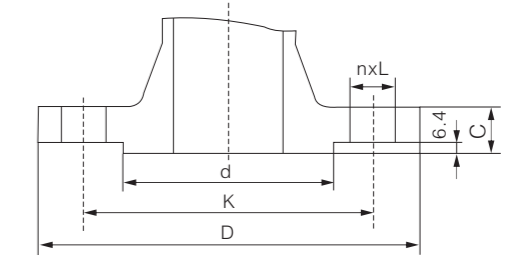

CLASS 400LB RF PN 6.8MPa raised-face

CLASS 150 RF Flange size

Size		D		K		d		n-L		C		Bolt diameter		Double bolt length	
DN	NPS	mm	in	mm	in	mm	in	mm	in	mm	in	mm	in	raised-face	ring
15	1/2	90	3.50	60.5	2.375	35	1.375	4-15	4-0.62	10	/	M14	1/2	55	/
20	3/4	100	3.875	70	2.75	43	1.6875	4-15	4-0.62	10	/	M14	1/2	65	/
25	1	110	4.25	79.5	3.125	51	2	4-15	4-0.62	12	0.44	M14	1/2	65	75
32	1 1/4	120	4.625	89	3.50	64	2.50	4-15	4-0.62	13	0.50	M14	1/2	70	85
40	1 1/2	130	5	98.5	3.875	73	2.875	4-15	4-0.62	15	0.56	M14	1/2	70	85
50	2	150	6	120.5	4.75	92	3.625	4-19	4-0.75	16	0.62	M16	5/8	85	95
65	2 1/2	180	7	139.5	5.50	105	4.125	4-19	4-0.75	18	0.69	M16	5/8	90	100
80	3	190	7.50	152.5	6	127	5	4-19	4-0.75	19	0.75	M16	5/8	90	100
100	4	230	9	190.5	7.50	157	6.1875	8-19	8-0.88	24	0.94	M16	5/8	90	100
125	5	255	10	216	8.50	186	7.3125	8-22	8-0.88	24	0.94	M20	3/4	90	110
150	6	280	11	241.5	9.50	216	8.50	8-22	8-0.88	26	1	M20	3/4	95	115
200	8	345	13.50	298.5	11.75	270	10.625	8-22	8-0.88	29	1.12	M20	3/4	100	120
250	10	405	16	362	14.25	324	12.75	12-25	12-1	31	1.19	M24	7/8	110	125
300	12	485	19	432	17	381	15	12-25	12-1	32	1.25	M24	7/8	115	135
350	14	535	21	476	18.75	413	16.25	12-29	12-1.12	35	1.38	M27	1	120	145
400	16	600	23.50	540	21.25	470	18.50	16-29	16-1.12	37	1.44	M27	1	135	145
450	18	635	25	578	22.75	533	21	16-32	16-1.25	40	1.56	M30	1 1/8	145	160
500	20	700	27.50	635	25	584	23	20-32	20-1.25	43	1.69	M30	1 1/8	160	170
600	24	815	32	749.5	29.50	692	27.25	20-35	20-1.38	48	1.88	M33	1 1/4	170	185
650	26	870	34.25	806.5	31.75	749	29.50	24-35	24-1.38	68	2.69	M33	1 1/4	210	/
700	28	927	36.50	863.6	34.00	800	31.50	28-35	28-1.38	71	2.81	M33	1 1/4	220	/
750	30	984	38.75	914.4	36.00	857	33.75	28-35	28-1.38	75	2.94	M33	1 1/4	230	/
800	32	1060	41.75	978	38.50	914	36.00	28-41	28-1.62	81	3.19	M39 x 3	1 1/2	255	/
850	34	1111	43.75	1029	40.50	965	38.00	32-41	32-1.62	83	3.25	M39 x 3	1 1/2	260	/
900	36	1168	46.00	1086	42.75	1022	40.25	32-41	32-1.62	90	3.56	M39 x 3	1 1/2	275	/
950	38	1238	48.75	1149.4	45.25	1073	42.25	32-41	32-1.62	87	3.44	M39 x 3	1 1/2	270	/
1000	40	1289	50.75	1200.2	47.25	1124	44.25	36-41	36-1.62	90	3.56	M39 x 3	1 1/2	275	/
1050	42	1346	53.00	1257.3	49.50	1194	47.00	36-41	36-1.62	97	3.81	M39 x 3	1 1/2	290	/
1100	44	1403	55.25	1314.5	51.75	1245	49.00	40-41	40-1.62	102	4.00	M39 x 3	1 1/2	300	/
1150	46	1454	57.25	1365.3	53.75	1295	51.00	40-41	40-1.62	103	4.06	M39 x 3	1 1/2	305	/
1200	48	1511	59.50	1422.4	56.00	1359	53.50	44-41	44-1.62	108	4.25	M39 x 3	1 1/2	310	/
1250	50	1568	61.75	1479.6	58.25	1410	55.50	44-48	44-1.88	111	4.38	M45 x 3	1 3/4	330	/
1300	52	1626	64.00	1537	60.50	1461	57.50	44-48	44-1.88	116	4.56	M45 x 3	1 3/4	340	/
1350	54	1683	66.25	1594	62.75	1511	59.50	44-48	44-1.88	121	4.75	M45 x 3	1 3/4	350	/
1400	56	1746	68.75	1651	65.00	1575	62.00	48-48	48-1.88	124	4.88	M45 x 3	1 3/4	355	/
1450	58	1803	71.00	1708.2	67.25	1616	64.00	48-48	48-1.88	129	5.06	M45 x 3	1 3/4	365	/
1500	60	1854	73.00	1759	69.25	1676	66.00	52-48	52-1.88	132	5.19	M45 x 3	1 3/4	375	/

Flange size

GENERAL VALVE

API SERIES

DIN SERIES

JIS SERIES

CLASS300 RF Flange size															
Size		D		K		d		n-L		C		Bolt diameter		Double bolt length	
DN	NPS	mm	in	mm	in	mm	in	mm	in	mm	in	mm	in	raised-face	ring
15	1/2	95	3.75	66.7	2.62	35	1.38	4-16	4-0.62	15	0.56	M14	1/2	65	75
20	3/4	120	4.62	82.5	3.25	43	1.69	4-19	4-0.75	16	0.62	M16	5/8	75	90
25	1	125	4.88	89	3.50	51	2.0	4-19	4-0.75	18	0.69	M16	5/8	75	90
32	1 1/4	135	5.25	98.5	3.88	64	2.50	4-19	4-0.75	19	0.75	M16	5/8	85	95
40	1 1/2	155	6.12	114.5	4.50	73	2.88	4-22	4-0.88	21	0.81	M20	3/4	90	100
50	2	165	6.50	127	5.0	92	3.62	8-19	8-0.62	23	0.88	M16	5/8	90	100
65	2 1/2	190	7.50	149	5.88	105	4.12	8-22	8-0.88	26	1	M20	3/4	100	115
80	3	210	8.25	168.5	6.62	127	5.0	8-22	8-0.88	29	1.12	M20	3/4	110	120
100	4	255	10	200	7.88	157	6.19	8-22	8-0.88	32	1.25	M20	3/4	115	125
125	5	280	11	235	9.25	186	7.31	8-22	8-0.88	35	1.38	M20	3/4	120	135
150	6	320	12.50	270	10.62	216	8.50	12-22	12-0.88	37	1.44	M20	3/4	120	140
200	8	380	15.0	330	13.0	270	10.62	12-26	12-1	42	1.62	M24	7/8	140	150
250	10	445	17.50	387.5	15.25	324	12.75	16-29	16-1.12	48	1.88	M27	1	160	170
300	12	520	20.50	451	17.75	381	15.0	16-32	16-1.25	51	2	M30	1 1/8	170	185
350	14	585	23.0	514.5	20.25	413	16.25	20-32	20-1.25	54	2.12	M30	1 1/8	180	190
400	16	650	25.50	571.5	22.50	470	18.50	20-35	20-1.38	58	2.25	M33	1 1/4	190	205
450	18	710	28.0	628.5	24.75	533	21.0	24-35	24-1.38	61	2.38	M33	1 1/4	195	210
500	20	775	30.50	686	27.0	584	23.0	24-35	24-1.38	64	2.50	M33	1 1/4	205	220
600	24	915	36.0	813	32.0	692	27.25	24-41	24-1.62	70	2.75	M39 x 3	1 1/2	230	255
650	26	972	38.25	876.3	34.50	749	29.50	28-45	28-1.75	79	3.12	M42 x 3	1 5/8	260	285
700	28	1035	40.75	934	37.00	800	31.50	28-45	28-1.75	86	3.38	M42 x 3	1 5/8	275	300
750	30	1092	43.0	997	39.25	857	33.75	28-48	28-1.88	92	3.62	M45 x 3	1 3/4	290	320
800	32	1149	45.25	1054.1	41.50	914	36.00	28-51	28-2.00	99	3.88	M48 x 3	1 7/8	310	340
850	34	1207	47.50	1105	43.50	965	38.00	32-51	32-2.00	102	4.00	M48 x 3	1 7/8	315	345
900	36	1270	50.00	1168.4	46.00	1022	40.25	32-54	32-2.12	105	4.12	M52 x 3	2	330	360
950	38	1168	46.00	1092.2	43.00	1029	40.50	32-41	32-1.62	108	4.25	M39 x 3	1 1/2	310	/
1000	40	1238	48.75	1156	45.50	1086	42.75	32-45	32-1.75	114	4.50	M42 x 3	1 5/8	330	/
1050	42	1289	50.75	1207	47.50	1137	44.75	32-45	32-1.75	119	4.69	M42 x 3	1 5/8	340	/
1100	44	1353	53.25	1264	49.75	1194	47.00	32-45	32-1.88	124	124	M45 x 3	1 3/4	355	/
1150	46	1416	55.75	1321	52.00	1245	49.00	28-51	28-2.00	129	129	M48 x 3	1 7/8	370	/
1200	48	1467	57.75	1372	54.00	1302	51.25	32-51	32-2.00	133	133	M48 x 3	1 7/8	380	/
1250	50	1530	60.25	1429	56.25	1359	53.50	32-55	32-2.12	140	140	M52 x 3	2	400	/
1300	52	1581	62.25	1480	58.25	1410	55.50	32-55	32-2.12	145	145	M52 x 3	2	410	/
1350	54	1657	65.25	1549	61.00	1467	57.75	28-60	28-2.38	152	152	M56 x 3	2 1/4	435	/
1400	56	1708	67.25	1600	63.00	1518	59.75	28-60	28-2.38	154	154	M56 x 3	2 1/4	440	/
1450	58	1759	69.25	1651	65.00	1575	62.00	32-60	32-2.38	159	159	M56 x 3	2 1/4	450	/
1500	60	1810	71.25	1702	67.00	1616	64.00	32-30	32-2.38	164	164	M56 x 3	2 1/4	460	/

Flange size

GENERAL VALVE

API SERIES

DIN SERIES

JIS SERIES

CLASS600 RF Flange size															
Size		D		K		d		n-L		C		Bolt diameter		Double bolt length	
DN	NPS	mm	in	mm	in	mm	in	mm	in	mm	in	mm	in	raised-face	ring
15	1/2	95	3.75	66.7	2.62	35	1.38	4-16	4-0.62	15	0.56	M14	1/2	75	75
20	3/4	120	4.62	82.5	3.25	43	1.69	4-19	4-0.75	16	0.62	M16	5/8	90	90
25	1	125	4.88	88.9	3.50	51	2.0	4-19	4-0.75	18	0.69	M16	5/8	90	90
32	1 1/4	135	5.25	98.4	3.88	64	2.50	4-19	4-0.75	21	0.81	M16	5/8	95	95
40	1 1/2	155	6.12	114.3	4.50	73	2.88	4-22	4-0.88	23	2.88	M20	3/4	110	110
50	2	165	6.50	127	5.0	92	3.62	8-19	8-0.75	26	1.00	M16	5/8	110	110
65	2 1/2	190	7.50	149.2	5.88	105	4.12	8-22	8-0.88	29	1.12	M20	3/4	120	120
80	3	210	8.25	168.3	6.62	127	5.0	8-22	8-0.88	32	1.25	M20	3/4	125	125
100	4	275	10.72	215.9	8.50	157	6.19	8-26	8-1.00	38	1.50	M20	7/8	145	145
125	5	330	13.0	266.7	10.5	186	7.31	8-29	8-1.12	45	1.75	M24	1	165	165
150	6	355	14.0	292.1	11.5	216	8.50	12-29	12-1.12	48	1.88	M27	1	170	170
200	8	420	16.50	349.2	13.75	270	10.62	12-32	12-1.25	56	2.19	M27	1 1/8	190	190
250	10	510	20.0	431.8	17.0	324	12.75	16-35	16-1.38	64	2.50	M30	1 1/4	215	215
300	12	560	22.0	489	19.25	381	15.0	20-35	20-1.38	67	2.62	M33	1 1/4	220	220
350	14	605	23.75	527	20.75	413	16.25	20-39	20-1.50	70	2.75	M36 x 3	1 3/8	235	235
400	16	685	27.0	603.2	23.75	470	18.50	20-42	20-1.62	77	3.00	M39 x 3	1 1/2	255	255
450	18	745	29.25	654	25.75	533	21.0	20-45	20-1.75	83	3.25	M42 x 3	1 5/8	275	275
500	20	815	32.0	723.9	28.50	584	23.0	24-45	24-1.75	89	3.50	M42 x 3	1 5/8	285	290
600	24	940	37.0	838.2	33.0	692	27.25	24-51	24-2.00	102	4.00	M48 x 3	1 7/8	330	335
650	26	1016	40.00	914.4	36.0	749	29.560	58-51	28-2.00	108	4.25	M48 x 3	1 7/8	350	360
700	28	1073	42.25	965.2	38.0	800	31.50	28-55	28-2.12	111	4.38	M52 x 3	2	360	380
750	30	1130	44.50	1022.4	40.25	857	33.75	28-55	28-2.12	114	4.50	M52 x 3	2	370	385
800	32	1194	47.00	1079.5	42.50	914	36.00	28-60	28-2.38	117	4.62	M56 x 3	2 1/4	380	400
850	34	1245	49.00	1130.3	44.50	965	38.00	28-60	28-2.38	121	4.75	M56 x 3	2 1/4	390	410
900	36	1314	51.75	1194	47.00	1022	40.25	28-67	28-2.62	124	4.88	M64 x 3	2 1/4	410	430
950	38	1270	50.00	1162	45.75	1054	41.50	28-60	28-2.38	152	6.00	M56 x 3	2 1/4	450	/
1000	40	1321	52.00	1213	47.75	1111	43.75	32-60	32-2.38	159	6.25	M56 x 3	2 1/4	465	/
1050	42	1403	55.25	1283	50.50	1168	46.00	28-67	28-2.62	168	6.62	M64 x 3	2 1/2	500	/
1100	44	1454	57.25	1333.5	52.50	1226	48.25	32-67	32-2.62	173	6.81	M64 x 3	2 1/2	510	/
1150	46	1511	59.50	1391	54.75	1276	50.25	32-67	32-2.62	179	7.06	M64 x 3	2 1/2	520	/
1200	48	1594	62.75	1460.5	57.50	1334	52.50	32-73	32-2.88	189	7.44	M70 x 3	2 3/4	555	/
1250	50	1670	65.75	1524	60.00	1384	54.50	28-80	28-3.12	197	7.75	M76 x 3	3	580	/
1300	52	1721	67.75	1575	62.00	1435	56.50	32-80	32-3.12	203	8.00	M76 x 3	3	595	/
1350	54	1778	70.00	1632	64.25	1492	58.75	32-80	32-3.12	210	8.25	M76 x 3	3	610	/
1400	56	1854	73.00	1695	66.75	1543	60.75	32-86	32-3.38	217	8.56	M82 x 3	3 1/4	635	/
1450	58	1905	75.00	1746	68.75	1600	63.00	32-86	32-3.38	222	8.75	M82 x 3	3 1/4	645	/
1500	60	1994	78.50	1822	71.75	1657	65.25	28-94	28-3.62	233	9.19	M90 x 3	3 1/2	680	/

Flange size

GENERAL VALVE

API SERIES

DIN SERIES

JIS SERIES

CLASS900 RF Flange size

Size		D		K		d		n-L		C		Bolt diameter		Double bolt length	
DN	NPS	mm	in	mm	in	mm	in	mm	in	mm	in	mm	in	raised-face	ring
15	1/2	120	4.75	82.6	3.25	35	1.38	4-22	4-0.88	22.5	0.88	M20	3/4	75	75
20	3/4	130	5.12	88.9	3.50	43	1.69	4-22	4-0.88	25.5	1.0	M20	3/4	90	90
25	1	150	5.88	101.6	4.0	51	2.0	4-26	4-1	29	1.12	M24	7/8	90	90
32	1 1/4	160	6.25	111.1	4.38	64	2.50	4-26	4-1	29	1.12	M24	7/8	95	95
40	1 1/2	180	7.0	123.8	4.88	73	2.88	4-29	4-1.12	32	1.25	M27	1	110	110
50	2	215	8.50	165.1	6.50	92	3.62	8-26	8-1	38.5	1.50	M24	7/8	110	110
65	2 1/2	245	9.62	190.5	7.50	105	4.12	8-29	8-1.12	41.5	1.62	M27	1	120	120
80	3	240	9.5	190.5	7.50	127	5.0	8-26	8-1	38.5	1.50	M24	7/8	145	145
100	4	290	11.5	235.0	9.25	157	6.19	8-32	8-1.25	44.5	1.75	M30	1 1/8	170	170
125	5	350	13.75	279.4	11.0	186	7.31	8-35	8-1.38	51	2.0	M33	1 1/4	190	190
150	6	380	15.0	317.5	12.50	216	8.50	12-32	12-1.25	56	2.19	M33	1 1/8	190	195
200	8	470	18.50	393.7	15.50	270	10.62	12-39	12-1.50	63.5	2.50	M36 x 3	1 3/8	220	220
250	10	545	21.5	469.9	18.50	324	12.75	16-39	16-1.50	70	2.75	M36 x 3	1 3/8	235	235
300	12	610	24.0	533.4	21.0	381	15.0	20-39	20-1.50	79.5	3.12	M36 x 3	1 3/8	255	255
350	14	640	25.25	558.8	22.0	413	16.25	20-42	20-1.62	86	3.38	M39 x 3	1 1/2	275	280
400	16	705	27.75	616	24.25	470	18.50	20-45	20-1.75	89	3.50	M42 x 3	1 5/8	285	290
450	18	785	31.0	685.8	27.0	533	21.0	20-51	20-2.0	102	4	M48 x 3	1 7/8	325	335
500	20	855	33.75	749.3	29.50	584	23.0	20-55	20-2.12	108	4.25	M52 x 3	2	350	360
600	24	1040	41.0	901.7	35.5	692	27.25	20-68	20-2.62	140	5.5	M64 x 3	2 1/2	440	455
650	26	1086	42.75	952.5	37.50	749	29.50	20-73	20-2.88	140	5.50	M70 x 3	2 3/4	455	480
700	28	1168	46.00	1022.3	40.25	800	31.50	20-80	20-3.12	146	5.62	M76 x 3	3	475	500
750	30	1232	48.50	1085.9	42.75	857	33.75	20-80	20-3.12	149	5.88	M76 x 3	3	485	515
800	32	1314	51.75	1155.7	45.50	914	36.00	20-86	20-3.38	159	6.25	M82 x 3	3 1/4	520	545
850	34	1394	55.00	1225.6	48.25	965	38.00	20-94	20-3.62	165	6.50	M90 x 3	3 1/2	540	580
900	36	1461	57.50	1289	50.75	1022	40.25	20-94	20-3.62	171.5	6.75	M90 x 3	3 1/2	565	595
950	38	1461	57.50	1289	50.75	1099	43.25	20-94	20-3.62	191	7.50	M90 x 3	3 1/2	605	615
1000	40	1511	59.50	1339.9	52.75	1162.0	45.75	24-94	24-3.62	197	7.75	M90 x 3	3 1/2	615	615
1050	42	1562	61.50	1390.7	54.75	1213	47.75	24-94	24-3.62	206	8.12	M90 x 3	3 1/2	635	635
1100	44	1648	64.88	1463.5	57.62	1270	50.00	24-99	24-3.88	214	8.44	M95 x 3	3 3/4	660	660
1150	46	1734	68.25	1536.7	60.50	1334	52.50	24-105	24-4.12	225.5	8.88	M100 x 3	4	690	690
1200	48	1784	70.25	1587.5	62.50	1384	54.50	24-105	24-4.12	233	9.19	M100 x 3	4	705	705

CLASS1500 RF Flange size

Size		D		K		d		n-L		C		Bolt diameter		Double bolt length	
DN	NPS	mm	in	mm	in	mm	in	mm	in	mm	in	mm	in	raised-face	ring
15	1/2	120	4.75	82.6	3.25	35	1.38	4-22	4-0.88	22.5	0.88	M20	3/4	110	110
20	3/4	130	5.12	88.9	3.5	43	1.69	4-22	4-0.88	25.5	1	M20	3/4	115	115
25	1	150	5.88	101.6	4	51	2.0	4-26	4-1	29	1.12	M24	7/8	125	125
32	1 1/4	160	6.25	111.1	4.38	64	2.50	4-26	4-1	29	1.12	M24	7/8	125	125
40	1 1/2	180	7	123.8	4.88	73	2.88	4-29	4-1.12	32	1.25	M27	1	140	140
50	2	215	8.5	165.1	6.5	92	3.62	8-26	8-1	38.5	1.50	M24	7/8	146	145
65	2 1/2	245	9.62	190.5	7.5	105	4.12	8-29	8-1.12	41.5	1.62	M27	1	160	160
80	3	265	10.5	203.2	8	127	5.0	8-32	8-1.25	48	1.88	M30	1 1/8	180	180
100	4	310	12.25	241.3	9.5	157	6.19	8-35	8-1.38	54	2.12	M33	1 1/4	195	195
125	5	375	14.75	292.1	11.5	186	7.31	8-42	8-1.62	73.5	2.88	M39 x 3	1 1/2	250	250
150	6	395	15.5	317.5	12.5	216	8.50	12-39	12-1.50	83	3.25	M36 x 3	1 3/8	260	265
200	8	485	19	393.7	15.5	270	10.62	12-45	12-1.75	92	3.62	M42 x 3	1 5/8	290	325
250	10	585	23	482.6	19	324	12.75	12-51	12-2	108	4.25	M48 x 3	1 7/8	335	345
300	12	675	26.5	571.5	22.5	381	15.0	16-55	16-2.12	124	4.88	M52 x 3	2	375	385
350	14	750	29.5	635	25	413	16.25	16-60	16-2.38	133.5	5.25	M56 x 3	2 1/4	405	425
400	16	825	32.5	704.8	27.75	470	18.50	16-68	16-2.62	146.5	5.75	M64 x 3	2 1/2	445	470
450	18	915	36	774.7	30.5	533	21.0	16-74	16-2.88	162	6.38	M70 x 3	2 3/4	495	525
500	20	985	38.75	831.8	32.75	584	23.0	16-80	16-3.12	178	7	M76 x 3	3	540	565
600	24	1170	46	990.6	39	692	27.25	16-94	16-3.62	203.5	8	M90 x 3	3 1/2	615	650

GENERAL VALVE

You are center of our world

